

XE 2000-HS ATOMIZER

USER'S MANUAL AND OPERATING INSTRUCTIONS

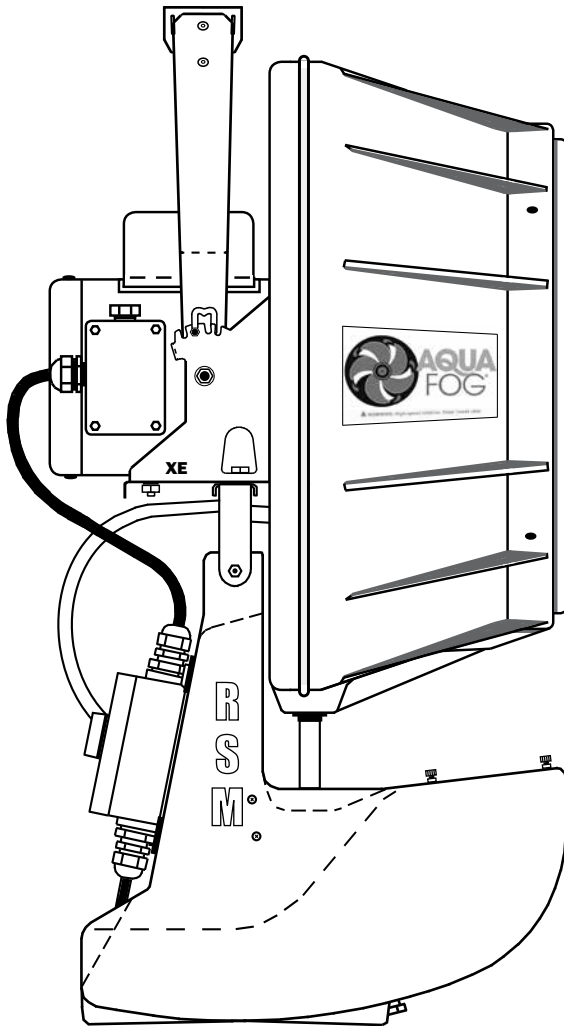

XE 2000-HS HANGING SUMP UNIT

- 115V 60Hz 1Ph
- 230V 50Hz 1Ph

UL and CSA Electrical Components

OPERATOR'S MANUAL

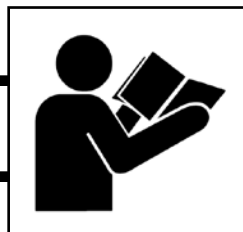

NOTICE

Read & Understand
Retain for Future Reference

TABLE OF CONTENTS

	PAGE
General Safety	3
Common Setups	4
Placement	5 - 6
Unpacking / Installation	7
Pivot / Utilities	8
Power Connection	9
Operation	10
Troubleshooting	11 - 12
XE 2000-HS Exploded View	13 - 14
Part Identification List	15
Oscillator Exploded View	16
Maintenance	17
Warranty	18

DESCRIPTION

Aquafoq units are intended to condition large volumes of air using water or other non-hazardous liquids at air temperatures between 33°F and 160°F. Any other use of these units will void the warranty and the manufacturer will not be responsible for problems or damages resulting from misuse.

Safety Guidelines

This manual contains very important information. This information will help ensure SAFETY and PREVENT EQUIPMENT PROBLEMS. Use these symbols to understand safety guidelines.

 **DANGER** DANGER INDICATES AN IMMEDIATELY HAZARDOUS SITUATION WHICH, IF NOT AVOIDED, WILL RESULT IN DEATH OR SERIOUS INJURY.

 **WARNING** WARNING INDICATES A POTENTIALLY HAZARDOUS SITUATION WHICH, IF NOT AVOIDED, COULD RESULT IN DEATH OR SERIOUS INJURY.

 **CAUTION** CAUTION INDICATES A POTENTIALLY HAZARDOUS SITUATION WHICH, IF NOT AVOIDED, MAY RESULT IN MINOR OR MODERATE INJURY.

 **NOTICE** NOTICE INDICATES IMPORTANT INFORMATION, THAT IF NOT FOLLOWED, MAY CAUSE DAMAGE TO EQUIPMENT.

Notes

GENERAL SAFETY

Since the XE 2000-HS uses high-speed components to atomize liquids, the following safety precautions must be observed at all times:

1. Read all manuals included with this product. Be familiar with the product and controls.
2. Follow United States Environmental Protection Agency (EPA) guidelines and regulations when fogging pesticide or chemical solutions.
3. Always operate XE 2000-HS with its safety guards and housing securely attached.
4. Follow all local electrical and safety codes as well as the United States National Electrical Codes (NEC) and Occupational Safety and Health Act (OSHA).
5. Only persons well acquainted with these rules of safe operation should be allowed to use the atomizer.
6. Keep visitors away and NEVER allow children in the work area.
7. Before each use, inspect blade assembly and electrical components for signs of damage, deterioration, weakness, or leakage. Repair or replace defective items before using.
8. Check all fasteners at frequent intervals for proper tightness.



⚠ WARNING

MOTORS, ELECTRICAL EQUIPMENT, AND CONTROLS CAN CAUSE ELECTRICAL ARCS THAT WILL IGNITE FLAMMABLE LIQUID OR GAS. NEVER OPERATE OR REPAIR IN OR NEAR FLAMMABLE LIQUID OR GAS. NEVER STORE FLAMMABLE LIQUIDS OR GASES IN THE VICINITY OF THE ATOMIZER.

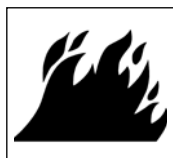

⚠ DANGER

HIGH-SPEED ROTATION

⚠ DANGER

KEEP SAFETY GUARDS ATTACHED AND IN GOOD WORKING CONDITION

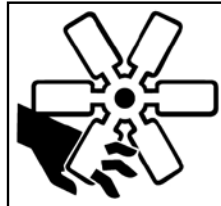

A motionless atomizer may appear safe, but its blade could suddenly begin high-speed rotation without warning as a result of control programming.

When the XE 2000-HS is automated by controls, warning signs should be posted near the high-speed equipment.

Disconnect and lock out power source to inspect or service the unit.

⚠ WARNING

NEVER OPERATE UNIT WITHOUT THE HOUSING INSTALLED.

9. Keep fingers away from a running unit; fast moving and hot parts will cause injury and/or burns.
10. If the equipment starts to vibrate abnormally, STOP the motor and check immediately for the cause. Vibration is generally an indication of trouble.

Fogging Precautions

⚠ DANGER

DO NOT ATOMIZE FLAMMABLE MATERIALS.

1. Humidity and cold air are two common asthma triggers. Asthmatic people working with this equipment need to be made aware of the risk.
2. When atomizing toxic chemicals, follow the instructions provided by the chemical manufacturer.

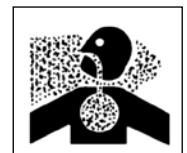

COMMON SETUPS

WATER FEED

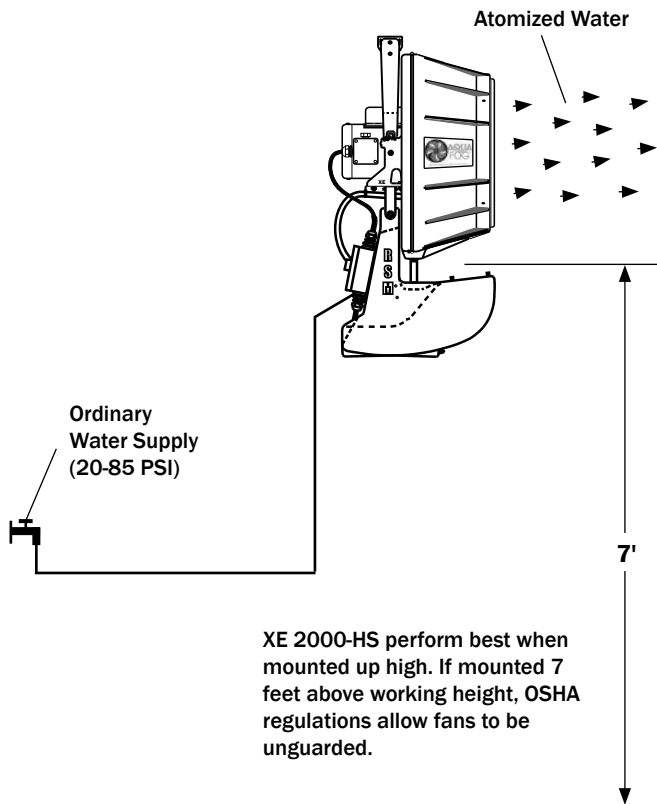

CHEMICAL INJECTION FEED

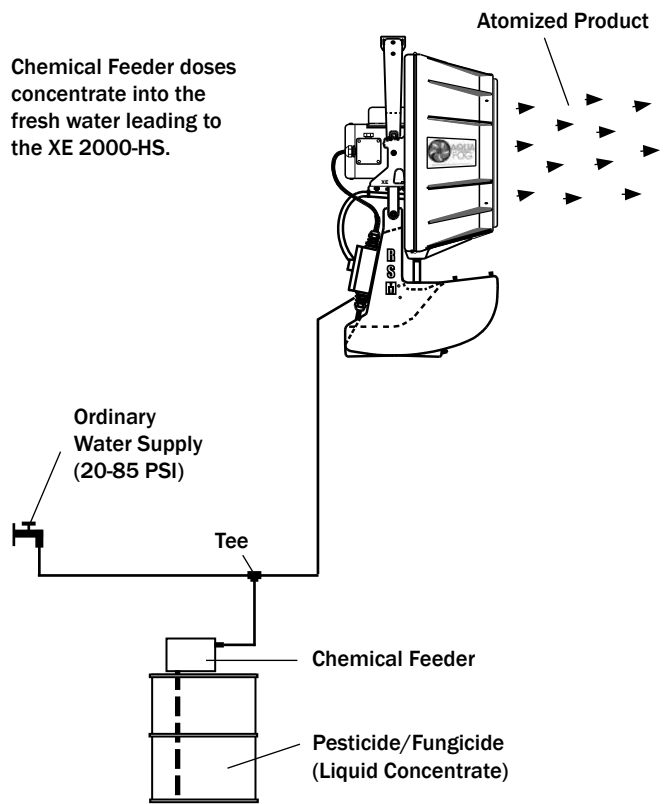

GRAVITY FEED

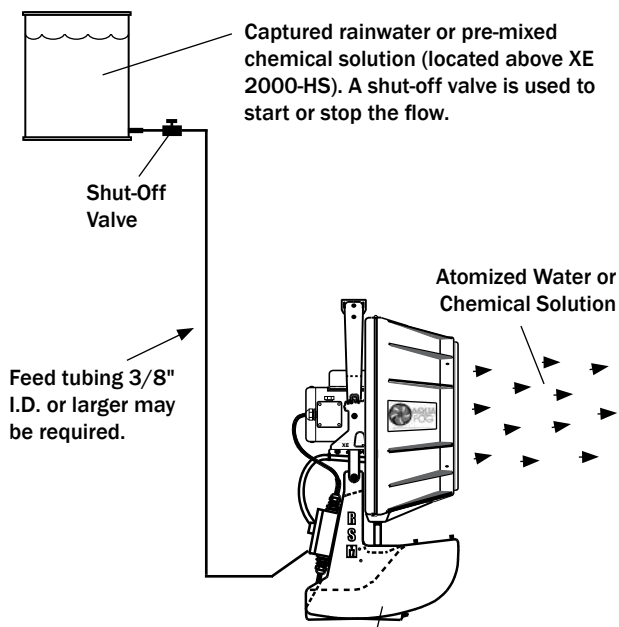

NOTE: During operation, the unit's Sump Tank must maintain an adequate water level. This is dependant on sufficient water flow from the gravity feed reservoir.

METERING PUMP FEED

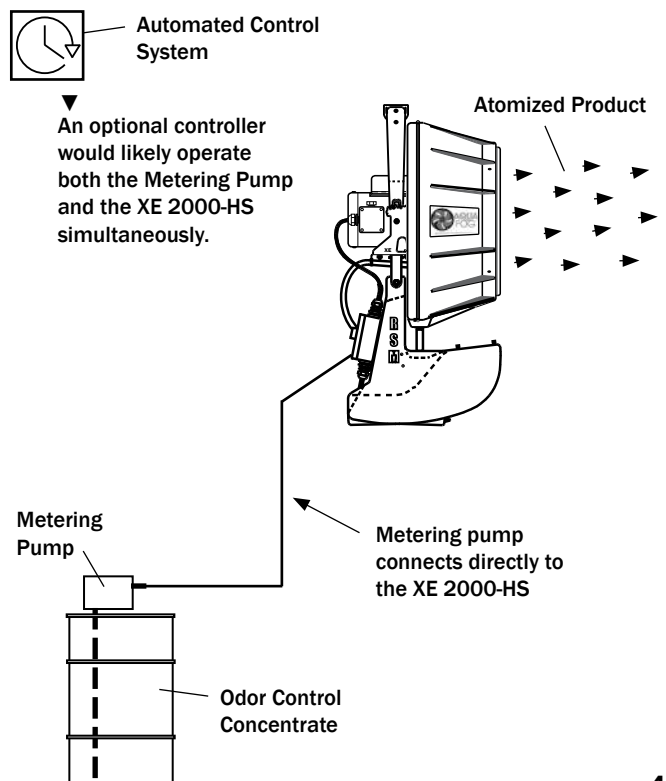

PLACEMENT



Placement Guidelines



NOTICE

TO HANG THE UNIT, USE A LEVEL 1" PIPE OR DRILLABLE FLAT AREA ABLE TO SUPPORT OVER 70 LBS.



Mount the fan high overhead. Allow room in front of and below the fan for the unobstructed propulsion of fog. Rule of thumb: the higher the better, but mount at least three feet away from any roofing structures.

Mount the fan at the intake end of a ventilated structure. In structures with mild to no ventilation, propel fog the length of the structure. In large structures, use of an oscillator greatly enhances coverage and circulation.

DO NOT: Mount the fan near the ground or underneath tables or benches.

DO NOT: Propel the fog into the wind (direction of airflow).

DO NOT: Cramp the fan in tight quarters or skinny aislesways.

Layout Guidelines

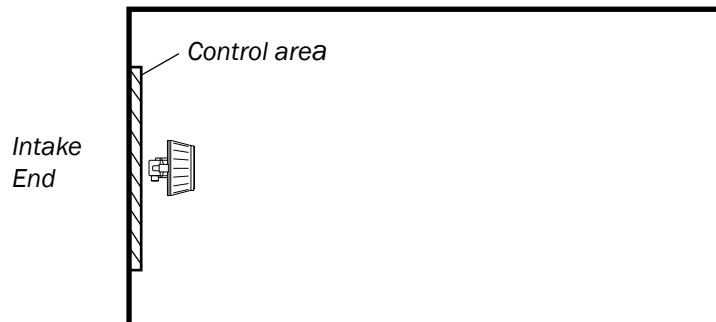

Small Structures

In applications requiring only one unit, mount the fan high, centered along one wall, with fog propelling horizontally along the length of the structure. If there is ventilation, mount the fan at the intake end of the structure. Generally, no oscillation is necessary unless the width of the structure is greater than 20'. The best location for automated controls is behind the fan, at an easily accessible level for monitoring.

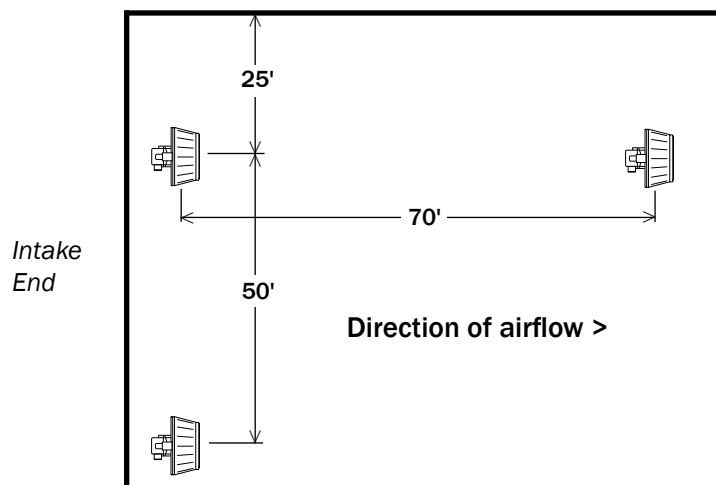

Large Structures, Forced Ventilation

In large structures equipped with forced ventilation, the first fan row should be within a few feet of the intake end, with first fan:

- centered along the end wall (or)
- placed no more than 25' from the side wall, with additional fans in the row equally spaced no more than 50' apart.

Lengthwise, the fans should be equally spaced no farther than 70' apart. All fans should be equipped with oscillation, sweeping 180° in the direction of airflow.

PLACEMENT (CONT.)

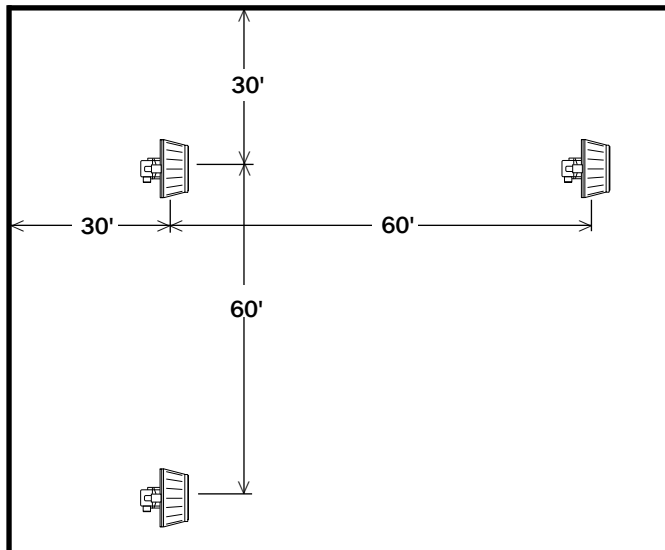

Large Structures, Natural Ventilation

In large structures with natural ventilation, propel fog the length of the structure with the first fan row no more than 30' from the end wall. The first fan should be:

- centered along the end wall (or)
- placed no more than 30' from the side wall, with additional fans in the row equally spaced no farther than 60' apart.

Lengthwise, the fans should be equally spaced and no more than 60' apart. All fans should be equipped with

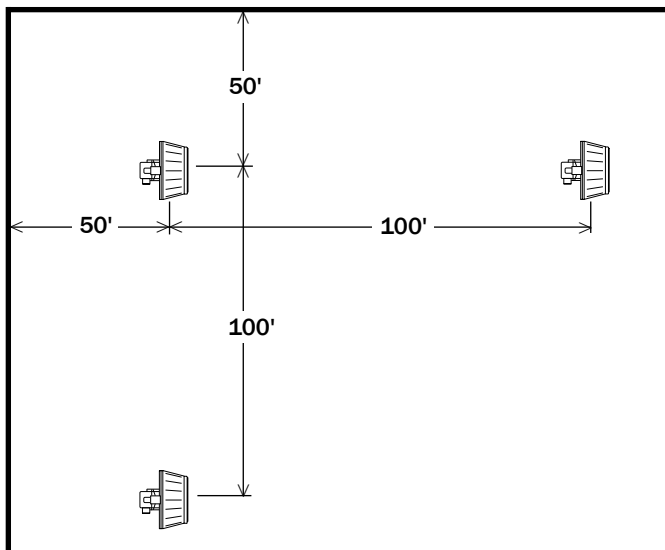

Large Structures, Closed or Minimum Ventilation

In closed structures with little to no ventilation, propel fog the length of the structure with the first fan row no more than 50' from the end wall. The first fan should either be:

- centered along the end wall (or)
- placed no more than 50' from the side wall, with additional fans in the row equally spaced no farther than 100' apart.

Lengthwise, the fans should be equally spaced and no farther than 100' apart. All fans should be equipped with oscillation, sweeping 360°.

UNPACKING

CHECKLIST

- (2) 1/4-20 Hanger U-bolt Package
- (1) 5/16-18 Universal Hanger Bolt Package
- (1) 5/32" Allen Wrench
- (1) 1/8" Allen Wrench
- (6) Wire Tie

TOOLS REQUIRED

- ▶ Level
- ▶ 7/16" Wrenches
- ▶ 1/2" Wrenches

⚠ WARNING

DO NOT OPERATE UNIT IF DAMAGED DURING SHIPPING, HANDLING OR USE. DAMAGE MAY RESULT IN BREAKAGE AND CAUSE INJURY OR PROPERTY DAMAGE.



After unpacking the unit, inspect for any damage that may have occurred during transit. Make sure to tighten fittings, bolts, etc. before operation.



⚠ DANGER

USING A LADDER TO HANG THE XE 2000-HS IS DANGEROUS. USE PROPER LIFTING EQUIPMENT LIKE A SCISSOR LIFT.

INSTALLATION

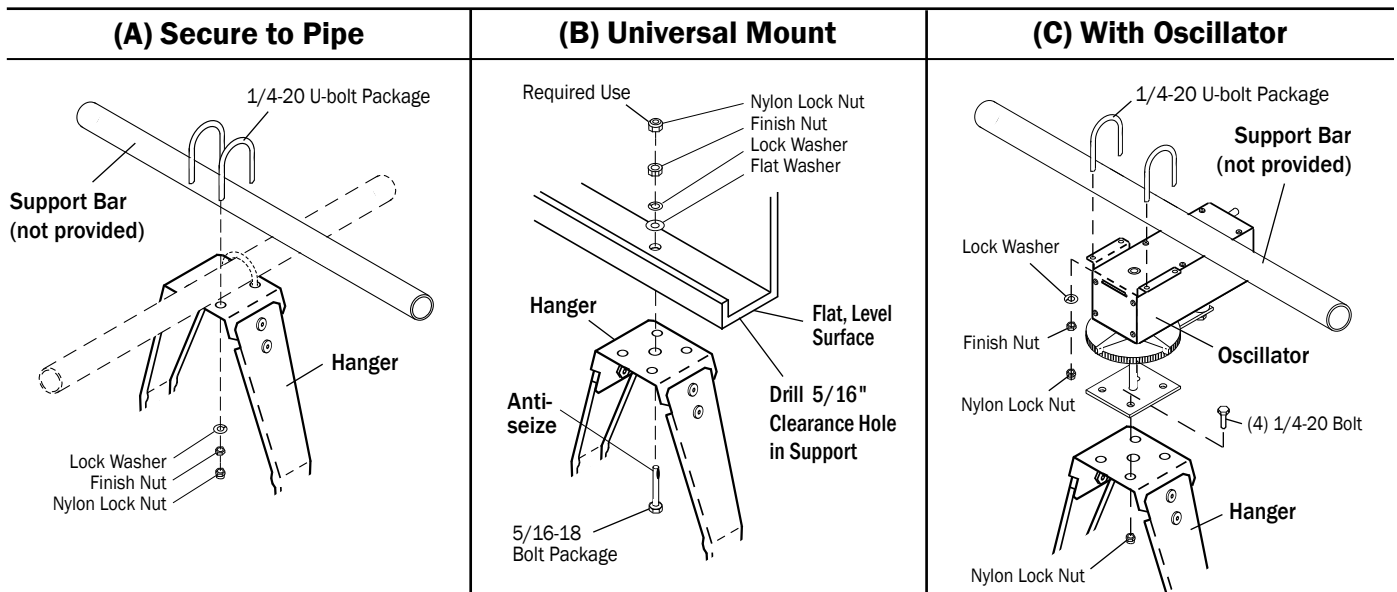

NOTE: THIS UNIT IS SPECIFICALLY DESIGNED ONLY TO BE HUNG WITH IT'S MOTOR IN THE UPRIGHT POSITION.

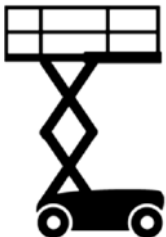

Securing To Pipe - Use U-bolts provided. Tighten securely. The nylon locknut should be tightened on top of the first nut to provide added protection.

Universal Mount - The support should be secure, level and flat. Drill a 5/16" clearance hole. It is **IMPORTANT** to tighten the second nylon locknut on top of the first nut to provide added protection. **Note:** Anti-seize applied to bolt prevents galling.

Installation with Oscillator - Support bar should be level. Use the U-bolts Package supplied with unit to secure Oscillator to bar. Use (4) 1/4-20 bolts with nylon lock nuts to attach the XE unit to the oscillator's support plate.

NOTE: TIGHTEN SECURELY USING TWO OPPOSING WRENCHES TO PREVENT STRESS ON OSCILLATOR'S INTERNAL GEARS.

PIVOT ADJUSTMENT

Pivot Locking System

After securing the XE 2000-HS, a pivot adjustment can be made to direct the fogging output to a desired location.

This unit has a positive pivot locking system with four available positions.

- ~ 5° up
- ~ Horizontal
- ~ 7° down
- ~ 14° down

To Make an Adjustment

Relieve the weight of the unit and lift one pivot lock up and rest it in the middle of the "M". While securely supporting the unit, lift the second lock up.

Adjust unit to desired angle. Re-engage both locks into the closest available slot.

NOTE: Use both sides of the "M" to access all four pivot angles.

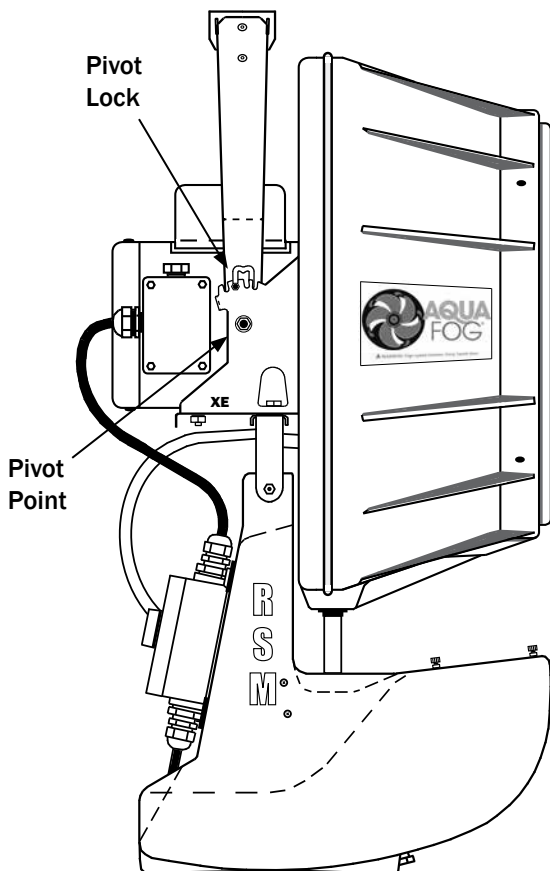

UTILITIES

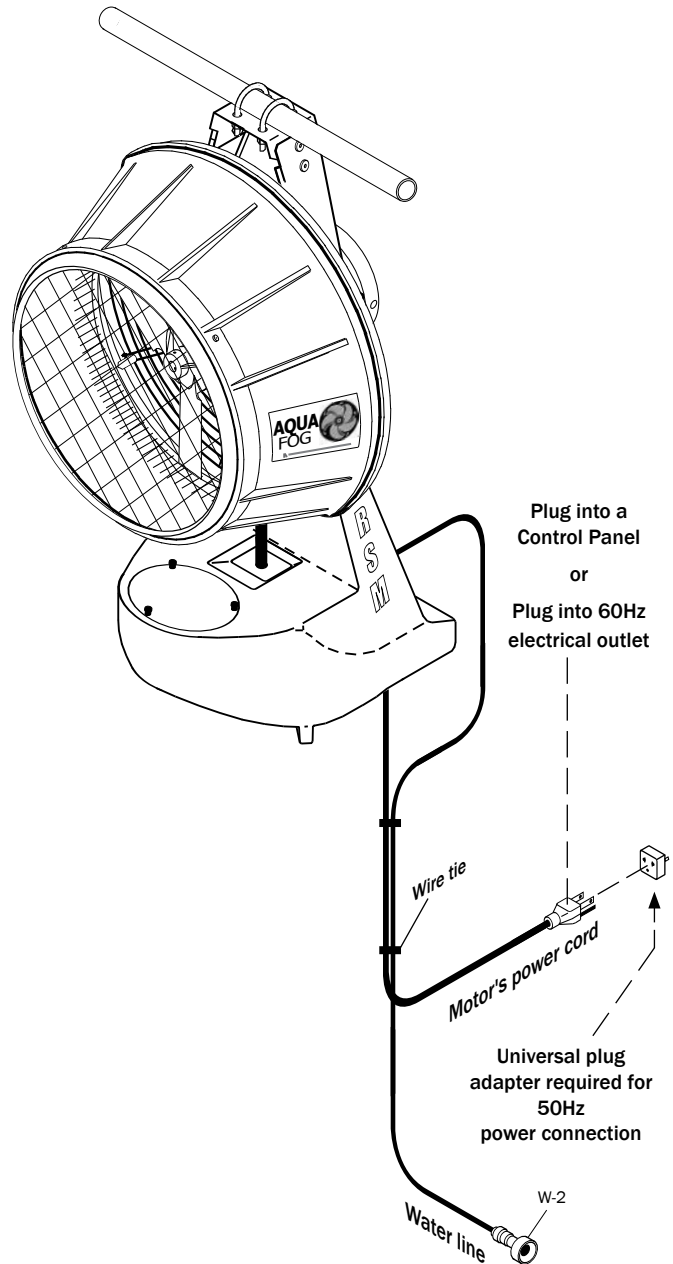

Water - Connect to an ordinary water supply with 20 PSI to 85 PSI:

- Directly to a garden hose
- Plumb into a water supply source

Drainage - Any waste water from the fan housing is directed into the unit's sump tank to be recycled.

Power - Connect to an ordinary power supply:

- Directly to a receptacle for manual operation
- To a controller for automation

POWER CONNECTION

WARNING

GROUND FAULT RECEPTACLE IS RECOMMENDED AND MAY BE REQUIRED BY LOCAL AND/OR NATIONAL CODE.



EXTENSION CORD SPECIFICATIONS*		
FOR SINGLE FAN USE ONLY • (AWG - American Wire Gauge)		
Voltage	25 to 50 ft.	50 to 100 ft.
115	16 AWG	14 AWG

*Grounded and suitable for outdoor use.



**PROPERLY
GROUND ALL
CONNECTIONS**

Wiring the Oscillator

WARNING

ALL WIRING AND ELECTRICAL CONNECTIONS MUST BE PERFORMED BY A QUALIFIED ELECTRICIAN.

Remove the black plug from the the top of the motor's junction box. Install the oscillator power cord and connector. This cord is pre-measured to the appropriate length. **DO NOT SHORTEN.**

Remove the motor junction box cover. Strip the ends of the oscillator power cord wires. Using the wire nuts provided, connect the oscillator cord wires and XE 2000-HS motor wires as shown in the appropriate wiring schematic. (See Page 17)

NOTE: XE 2000-HS motors are dual voltage and can operate either on high or low voltage. For connection changes, refer to the electrical schematic located on the motor.

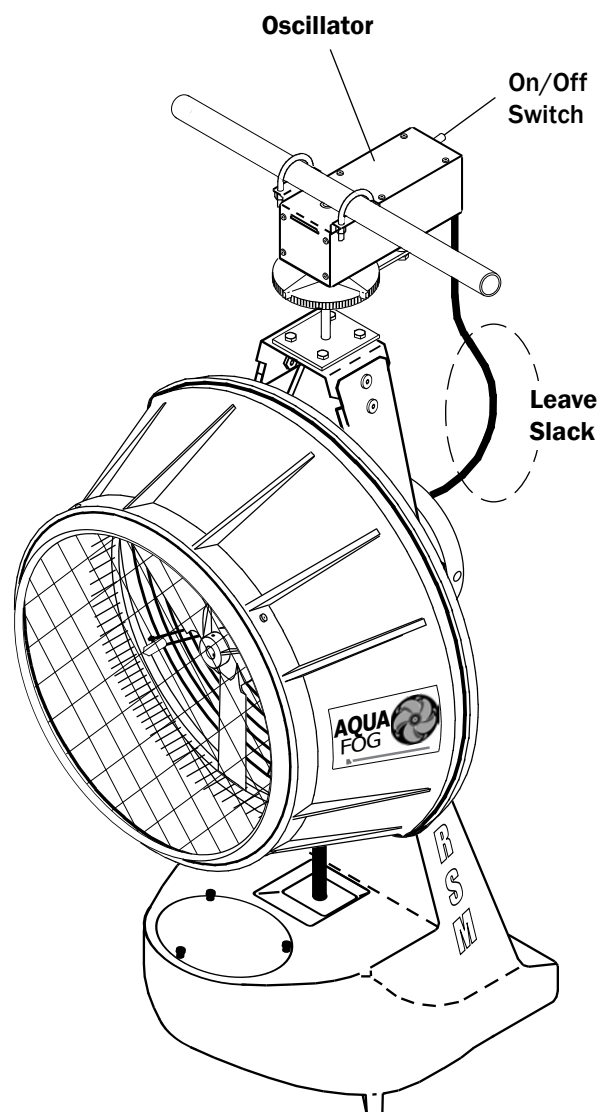

OPERATION

⚠ DANGER

BEFORE TESTING FAN, MAKE SURE ALL OBJECTS ARE OUT OF THE ROTATION PATH OF THE FAN BLADES. HIGH-SPEED WARNING. KEEP HANDS CLEAR! MAKE SURE GUARDS ARE INSTALLED OR UNIT IS OUT OF REACH.



BUMP START XE 2000-HS and check for proper fan blade rotation (clockwise if looking at front of unit). If incorrect, find rotation connection changes on the motor's electrical schematic.

⚠ CAUTION

LISTEN FOR UNUSUAL NOISE OR VIBRATION.

Turn on the water supply, let the tank fill, and then turn on the fan motor. Listen for any possible abnormalities, such as the blades rubbing against the venturi and make adjustments if necessary. If no problems are detected, slowly open the flow control valve until the desired fogging output is achieved.

If using an oscillator, check the rotational movement and be SURE THE POWER CORD HAS ENOUGH SLACK. If there is not enough, try re-mounting the XE 2000-HS with the oscillator power cord falling in line with its motor.

⚠ NOTICE

XE 2000-HS CANNOT BE OPERATED DRY

XE 2000-HS

Operational Controls

The volume of fog can be regulated by adjusting the Flow Control Ball Valve.

Particle size is smaller at lower outputs, so it is better to operate the fan at a lower output for a longer period of time.

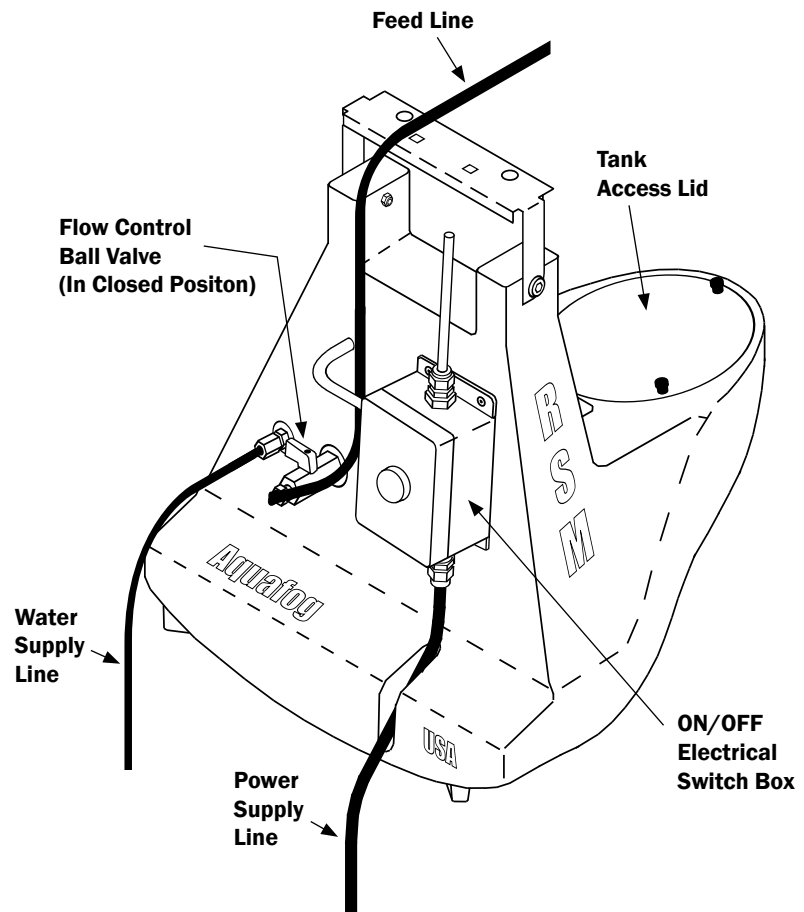

TROUBLESHOOTING



WARNING

***BEFORE INSPECTION AND/OR SERVICE,
DISCONNECT AND LOCK OUT POWER SOURCE.***

1. Fan Does Not Operate

- A.) Check voltage requirements on unit and electrical supply. Check for live receptacle, plug, power line and unit's power On/Off switch.
- B.) Look for any loose connections inside the main motor's junction box.

2. Unusual Noise

Squealing at start-up or during operation may be caused by the motor shaft's bearing seal. Spray with lubricant at the front of the motor where the shaft exits the motor's frame.

3. No Fog

- A.) If the Flow Control Valve is closed, turn the knob in-line with the valve to open fogging output. Visually check Feed Line connections leading to the atomizing blade assembly.
- B.) If the unit is automated with a controller, check to see if power is being supplied to the unit when the controller is on.
- C.) If after checking both the Flow Valve and Controller, if you still do not have any fog, begin a process of elimination starting with the Feed Pump located in the sump tank. Disconnect and reconnect your plumbing before and after each device to check for any obstructions or electrical failures.

4. Poor Quality Fog

- A.) The liquid feed tube (Part #575) may not be properly positioned. The feed tube is located behind the blade assembly and should be inserted approximately 1/4" into the slot between the motor shaft and the stainless steel face plate. Centered in the slot area and aimed slightly downward, free from any rotational contact.
- B.) Liquid not traveling through the fan blades. This can be diagnosed by viewing the back of a blade assembly during operation (using a bright flashlight). If system is clogged, liquid can be seen spinning out of the slot area between the motor shaft and stainless steel face plate (Part #573). If confirmed, replace fan blade assembly (Part #571-assy). Cleaning the internal passageways of a blade assembly is feasible with the aid of some speciality tools.

5. Fog Slowly Decreases

If fog output gradually decreases over time, check for kinks in the water supply lines. Check to make sure the float valve assembly is maintaining a full tank (fully submerging the pump at all times). If the problem persists, sediment may be slowly building around the inlet screen of the pump located in the sump tank. Try cleaning this area by removing the tank's drainage plug (Part #481) to flush out the dirty water.

TROUBLESHOOTING (CONT.)



**BEFORE INSPECTION AND/OR SERVICE,
DISCONNECT AND LOCK OUT POWER SOURCE.**



6. Fan Motor Becomes Excessively Hot

The main fan motor normally becomes very hot to the touch. However, if it gets so hot that it begins to smell or smoke or the power cord becomes hot, discontinue operation and consult an electrician to properly evaluate the problem.

7. Electrical Breaker Tripping

If the electrical breaker trips off, there is an overload in the system and there may be a serious motor problem. Turn off all other devices connected to the same circuit. If the breaker continues to trip, the motor is probably in need of repair. Consult an electrician for evaluation.

8. Fan and/or Motor Vibration

A.) If the fan unit begins vibrating severely, first be sure the blade assembly is fully engaged and securely tightened on the motor shaft. Next, inspect the blade assembly, particularly the ends of the blades. Look for wear or cracks - replace as necessary. Look for deposits of calcium or minerals - clean and remove mineral deposits and/or calcium.

B.) If the vibration seems to be coming from the motor, first check that the motor mounting hardware is securely tightened. If hardware is secure, remove the blade assembly and operate the motor without the blade. If vibration continues, the motor has a serious mechanical problem and probably needs to be replaced.

9. Liquid Spilling From Fan Housing or Sump Tank

If liquid builds up inside the housing, the drain tube is clogged. Clean debris from around the drain inside the housing and flush drain tube. If liquid overflows from the sump, check the floatvalve assembly (400-012) for any impediments preventing the valve from closing properly when tank becomes full. Replace if necessary.

10. Plumbing Leaks

Un-thread fittings and clean both the male and female threads. Apply new thread tape (approximately 2-3 wraps) and reconnect. If a tube fitting is leaking, tighten the cap - no more than 1 turn past finger tightened. If the leak persists, replace the tube fitting insert.

Contact Your Sales Representative for Further Assistance.

XE 2000-HS EXPLODED VIEW

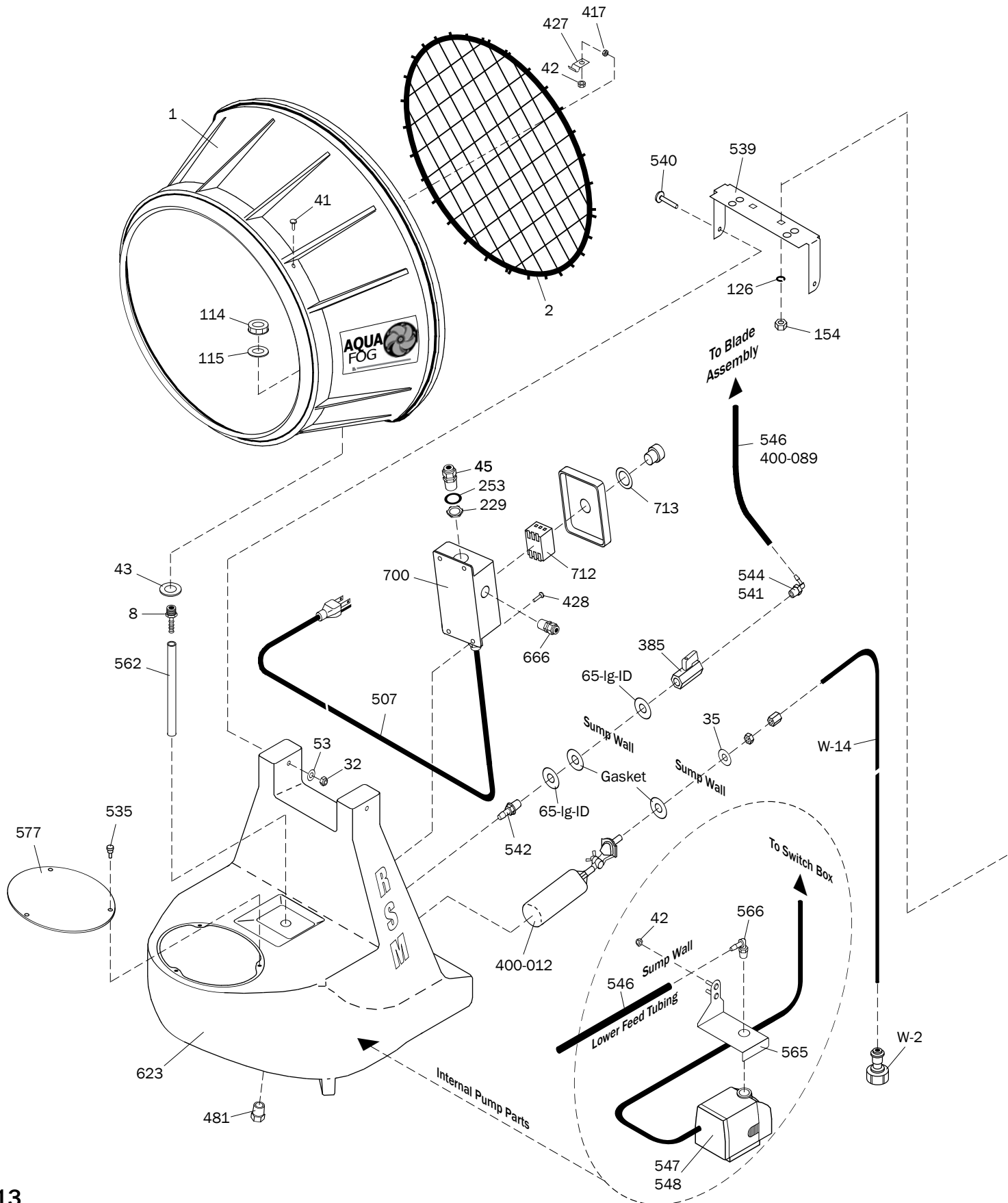

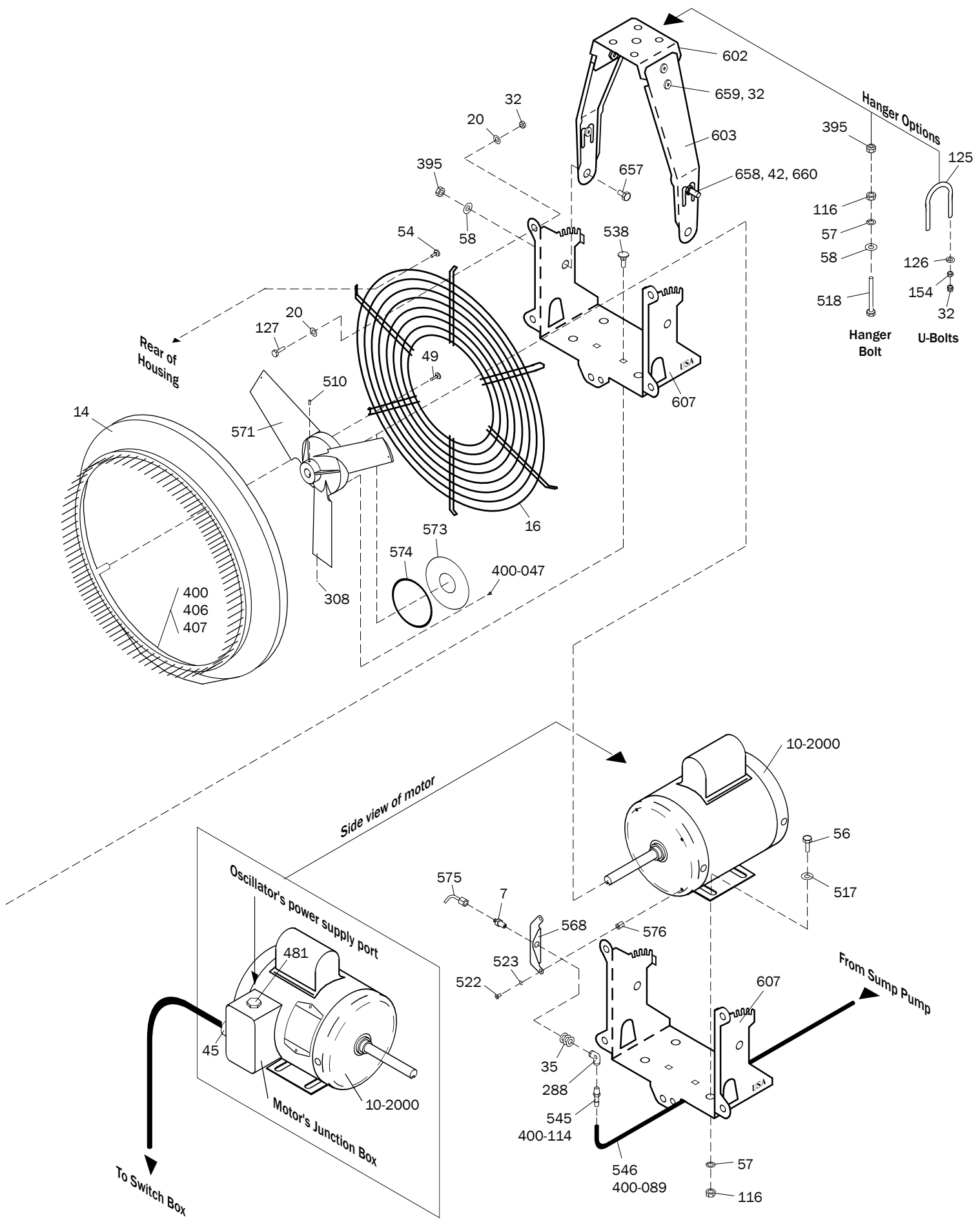

PART IDENTIFICATION LIST (XE 2000-HS)

ID #	Description	Qty per Unit	ID #	Description	Qty per Unit
<u>XE 2000-HS COMPONENTS</u>					
1	XE Housing	1	507	115V Power cord (for 60/50Hz models)	1
2	Safety guard	1	510	#10 Set screw	2
7	Liquid feed tube fitting	1	517	5/16 Small ID washer SST	4
8	Drain fitting	1	518	5/16-18 x 2" HH bolt SST	1
10-2000	XE-2000 Washdown motor 60/50Hz	1	522	10-32 x 1/4" button head screw	
14	Pinned venturi assembly	1	2		
16	Rear guard	1	523	#10 Lock washer	2
20	1/4" thick washer	10	535	10-24 nylon thumb screw	3
32	1/4-20 nylon stop nut SST		538	1/4-20 x 5/8" carriage bolt SST	2
15			539	RSM SST hanger bracket	1
35	Valve washer	4	540	1/4-20 x 1-1/4" button head cap screw SST	2
41	10-24 x 5/8" phillips RH SST	4	541	1/4 NPT x 1/4" barb elbow (50Hz model)	1
42	10-24 nylon stop nut SST	8	542	1/4 NPSM x 3/8" barb (PM) (60Hz models)	1
43	Drain washer SST	1	544	1/4 NPT x 3/8" barb elbow (60Hz models)	1
45	Liquid-tight connector	3	545	1/8 NPT x 3/8" barb (60Hz models)	1
53	1/4" flat washer SST	2	546	1/2" OD PVC (upper) tubing (60Hz models)	2'
65-Ig-ID	1-1/4" x 9/16" flat washer SST	2	547	GT-RSM pump (for 60Hz models)	1
49	10-24 x 1/2" phillips truss head SST	4	548	GT-RSM pump (for 50Hz model)	1
54	1/4-20 x 3/8" button head cap screw	6	558	Sm. grommet (for 50Hz models)	1
56	5/16-18 x 3/4" HH bolt SST	4	562	RSM Drain tubing	1'
57	5/16" lock washer SST	5	565	Pump support assembly	1
58	5/16" flat washer SST	3	566	1/2 x 3/8" Barbed elbow	1
114	Drain fitting nut	1	568	XE Feed tube support SST	1
115	Drain gasket	1	571	XE Rear-feed blade assembly	1
116	5/16-18 finish nut	5	573	XE Rear-feed face plate SST	1
125	1/4-20 U-bolt SST	2	574	XE Rear-feed o-ring	1
126	1/4" lockwasher SST	6	575	XE Reer-feed tube assembly	1
127	1/4-20 x 7/8" HH bolt SST	5	577	RSM 2000 Lid	1
154	1/4-20 finish nut SST	6	576	10-32 x 1/2" brass standoff	2
229	Galv. Locknut	2	602	XE Hanger top SST	1
253	O-ring	2	603	XE Hanger side SST	2
288	1/8" NPT elbow	1	607	XE Motor plate SST	1
308	1-72 x 3/32" setscrew SST	3	623	RSM 2000 Sump tank	1
385	1/4" NPT mini ball valve	1	657	5/16-18 x 5/8" HH bolt SST	2
395	5/16-18 nylon stop nut SST	3	659	1/4-20 x 5/8" button HCS SST	4
400	Foam drip sponge	1	658	10-24 x 1" phillips truss MS SST	2
400-012	Float valve assembly	1	660	Pivot, vinyl cap	2
400-047	Reservoir plate SST screw	8	666	3/8 NPT Liquid-tight connector	1
400-089	3/8" OD PVC (upper) tubing (50Hz model)	2'	712	ON/OFF Push Button Switch	1
400-108	Lg. silicone grommet (for 60Hz models)	1	713	Switch Washer	1
400-114	1/8" NPT x 1/4" barb (50Hz model)	1	W-2	Hose connector	1
406	Nylon rivet	6	W-14	1/4" Poly tubing	20'
407	Rivet washer	6			
417	10-24 Machine nut SST	4			
427	Safety guard clip	4			
428	10-24 x 3/8" screw SST	2			
481	1/2" black hex plug	2			

OSCILLATOR EXPLODED VIEW

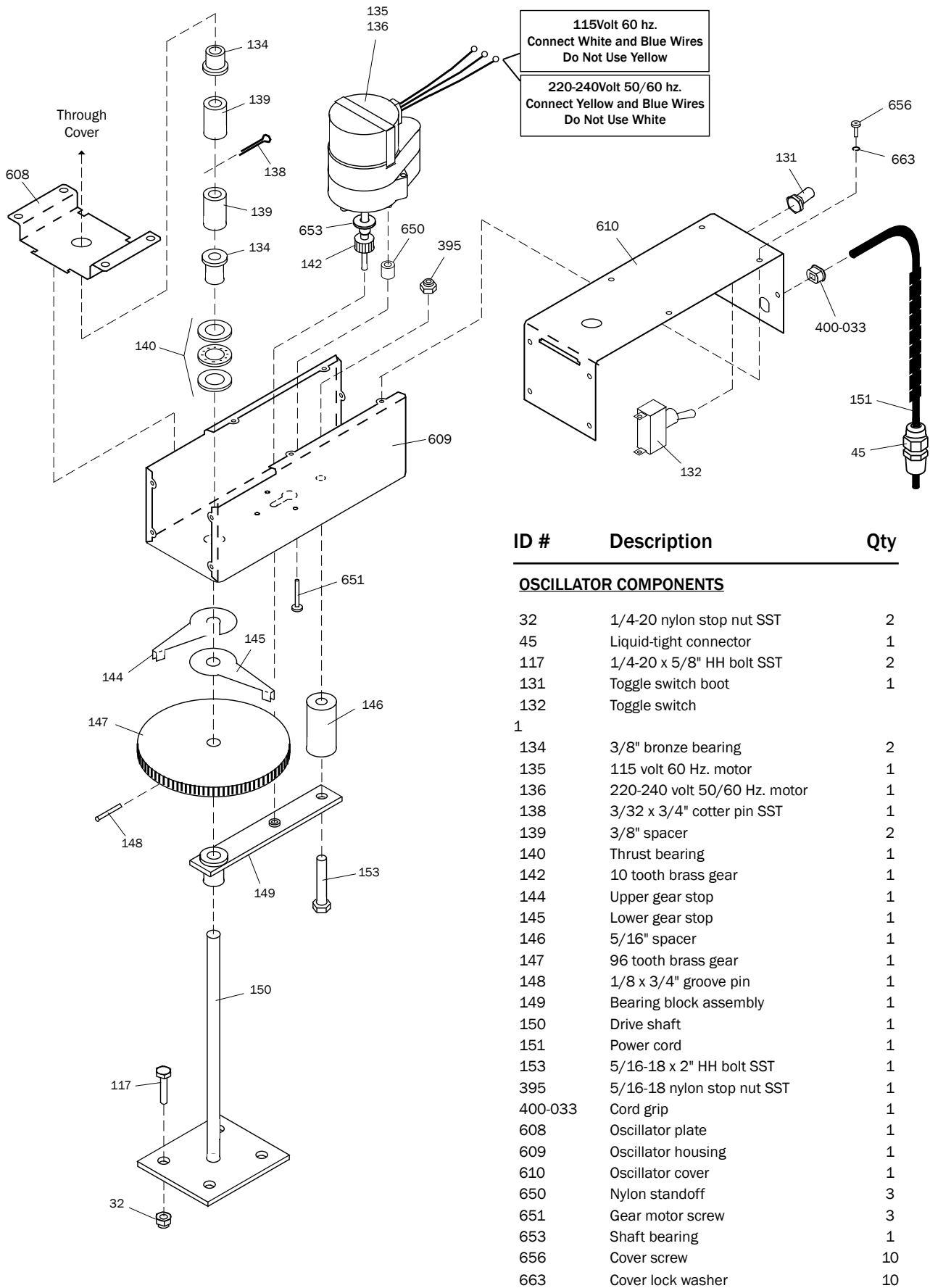

MAINTENANCE



⚠ WARNING

DISCONNECT AND LOCK OUT POWER SOURCE BEFORE SERVICING

1. Inspect Blade Assembly

Clean the the exterior of the blades about once a year or whenever a film of calcium or mineral deposits is visible. While cleaning, inspect for irregularities or hairline cracks and replace as necessary.

2. Flush Out Tank

The tank should be rinsed regularly, especially if using chemicals. Remove drain plug (Part #481) and, using a garden hose, thoroughly flush tank and pump of any sediment.

3. Main Motor

The main motor is a permanently lubricated motor, but occasionally applying some spray oil to external rusty areas of the motor's body can help extend the motor's life.

5. Storage

Protect your Aquafog from winter damage. Expansion due to freezing can burst fittings, solenoids and flowmeters. If storing unit in below freezing temperatures, be sure all fluid is drained from the unit. Damage due to freezing is not covered under warranty.

ELECTRICAL SCHEMATICS

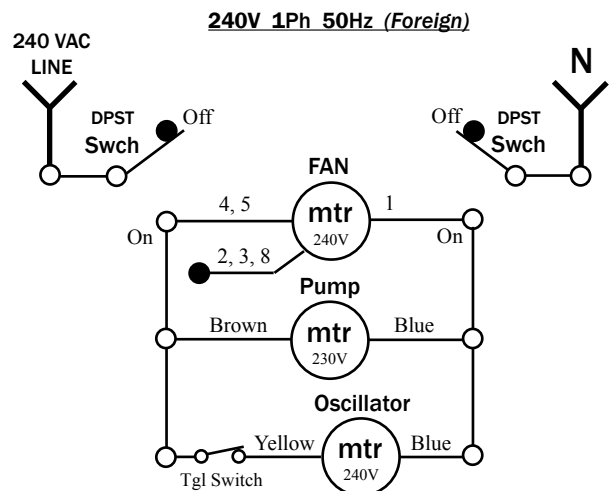
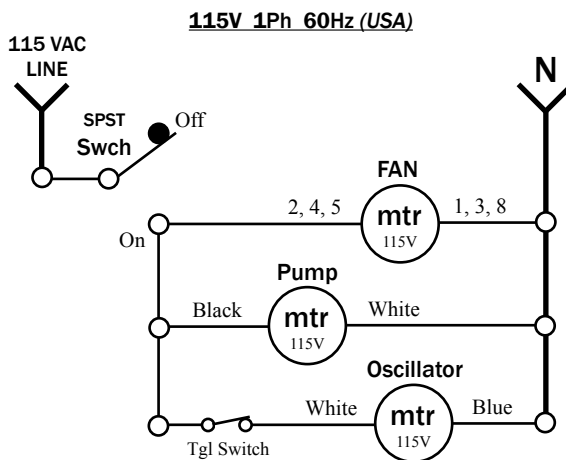

Electrical Schematic Code Designation

○ Denotes Line Connection

● Denotes Wire Nut Termination

Note: All green wires go to ground





ONE YEAR LIMITED WARRANTY

Aquafog and accessories are warranted to the original purchaser against defects in material and workmanship under normal use for one full year from date of purchase. Any part determined to be defective and returned to the manufacturer, shipping cost prepaid, will be repaired or replaced at Jaybird Manufacturing, Inc.'s discretion without charge. Proof of purchase date and an explanation of the problem or complaint must accompany the returned portion of the machine.

Jaybird Manufacturing, Inc. reserves the right to verify the legitimacy of claimed defects. The provisions of this warranty do not apply to damage resulting from direct or indirect misuse, negligence, accident, lack of maintenance, or unauthorized repairs or alterations which affect the machine's performance or reliability.

LIMITATIONS OF LIABILITY. TO THE EXTENT ALLOWABLE UNDER APPLICABLE LAW, JAYBIRD MANUFACTURING, INC.'S LIABILITY FOR DEATH, INJURIES TO PERSONS OR PROPERTY, OR FOR CONSEQUENTIAL OR INCIDENTAL DAMAGES ARISING FROM THE USE OF OUR EQUIPMENT IS EXPRESSLY DISCLAIMED. JAYBIRD MANUFACTURING, INC.'S LIABILITY IN ALL EVENTS IS LIMITED TO, AND SHALL NOT EXCEED, THE PURCHASE PRICE PAID. NO OTHER WARRANTY, EXPRESSED OR IMPLIED, IS AUTHORIZED, INCLUDING WARRANTIES OF MERCHANTABILITY AND FITNESS FOR A PARTICULAR PURPOSE.

This warranty gives you specific legal rights, and you may also have other rights, which vary from state to state.

