

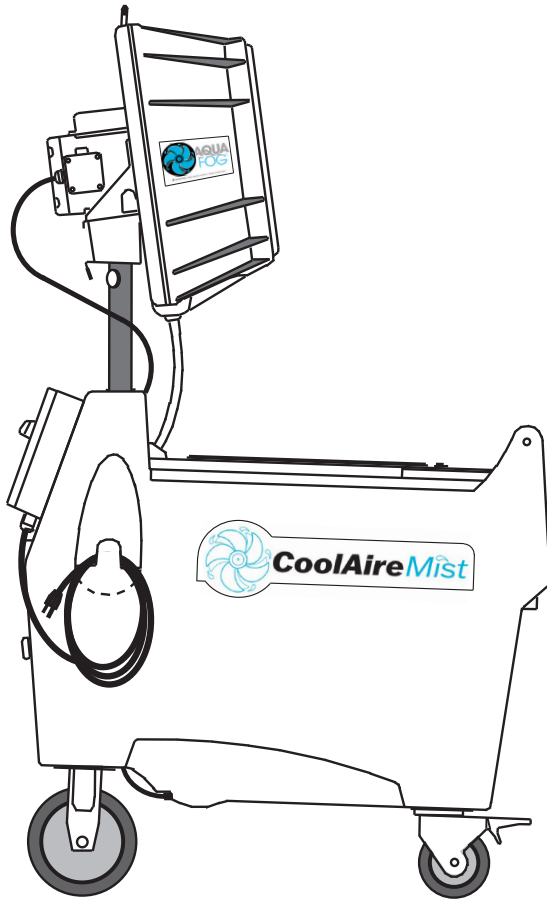

Mobile Mist Cooler

- ▶ COOL-101
- ▶ COOL-102



OPERATOR'S MANUAL



NOTICE

Read & Understand
Retain for Future Reference

Purchase Date _____ Model ID Number _____

Vendor Information _____

Notes

TABLE OF CONTENTS

PRODUCT USE

	PAGE
General Safety	3
Unpacking & Setup	4
Operation & Maintenance	5
Troubleshooting	6
Service & Repair	7
Electrical Schematic	8
Replacement Part ID	9
Warranty	10

Aquafog (CoolAire) mobile units are intended to condition large volumes of air using water or other non-hazardous liquids at air temperatures between 33°F and 145°F. Any other use of this unit would likely void the warranty and any manufacturer's responsibilities.

SAFETY NOTIFICATIONS

This manual contains very important information. This information will help ensure SAFETY and PREVENT EQUIPMENT PROBLEMS. Below are important safety guidelines.

WARNING

THE COOLAIRE MIST CAN BE AUTOMATED WHEN USED IN CONJUNCTION WITH A CONTROL. THE FAN MAY NOT APPEAR POWERED BUT COULD SUDDENLY BEGIN HIGH-SPEED ROTATION AS A FUNCTION OF THE PRESET CONTROL.

DANGER

A WATER RESERVOIR (COOLAIRE'S TANK) CAN BRING THE RISK OF DROWNING. DROWNING ACCIDENTS CAN BE PREVENTED WITH PROPER PRECAUTIONS, SUPERVISION AND KNOWLEDGE. CHILDREN CAN DROWN IN LESS THAN ONE MINUTE. PERSONNEL WORKING WITH COOLAIRE MIST SHOULD BE PROPERLY TRAINED.

CAUTION

HIGH-SPEED ROTATION, NEVER OPERATE UNIT WITHOUT THE HOUSING AND SAFETY GUARDS INSTALLED.

NOTICE

GROUND FAULT RECEPTACLES ARE STRONGLY RECOMMENDED AND MAY BE REQUIRED BY LAW.

GENERAL SAFETY

The **CoolAire Mist** uses a high-speed component to atomize water and a water reservoir to hold water supplies. The following safety precautions must be observed at all times:



1. Read operator's manual carefully and thoroughly. Understand all safety warnings and instructions before attempting operation of the unit.
2. **DO NOT OPERATE THE PUMP DRY (WATER SUPPLY IS REQUIRED IN THE SUMP).** Avoid permanent damage to the unit's sump pump. Turn off "MIST" (pump switch) to operate the unit air only.
3. Follow all local electrical and safety codes as well as the United States National Electrical Codes (NEC) and Occupational Safety and Health Act (OSHA).
4. Keep children from playing with CoolAire Mist. Supervise nearby children or blockade area to prevent children from accidentally falling into the tank. Keep the lid installed.
5. Always operate CoolAire Mist with it's safety guards, housing and lid securely in place. Use front wheel locks at all times.
6. Disconnect power before inspecting or servicing machine. CoolAire Mist must be properly grounded as a precaution against possible electric shock. Check for correct voltage supply.
7. Keep cord away from heat, oil, sharp edges and moving parts. Replace damaged cords immediately. Damaged cords increase the risk of electric shock.
8. If using an extension cord. Use a heavy gauge 3 wire extension cord with a molded three-prong plug rated for outdoors.
9. Keep hands and all objects from entering the path of the blade.
10. Use fresh water supplies. Do not use flammable liquids, caustic materials, or corrosive materials with the CoolAire Mist.
11. When servicing CoolAire Mist, use only identical replacement parts and follow instructions in the maintenance section of this manual. Use of unauthorized parts or failure to follow maintenance instructions may damage equipment or cause personal injury.

UNPACKING

Receiving your CoolAire Unit

Locate and remove the screws securing the box to the skid. Lift and save the box in case a return is necessary. Remove the strapping and unpack the unit. Inside the tank locate the following:

- 1) Atomizing Fan Head
- 1) Column Assembly
- 1) Operators Manual/Service Bag



SETUP

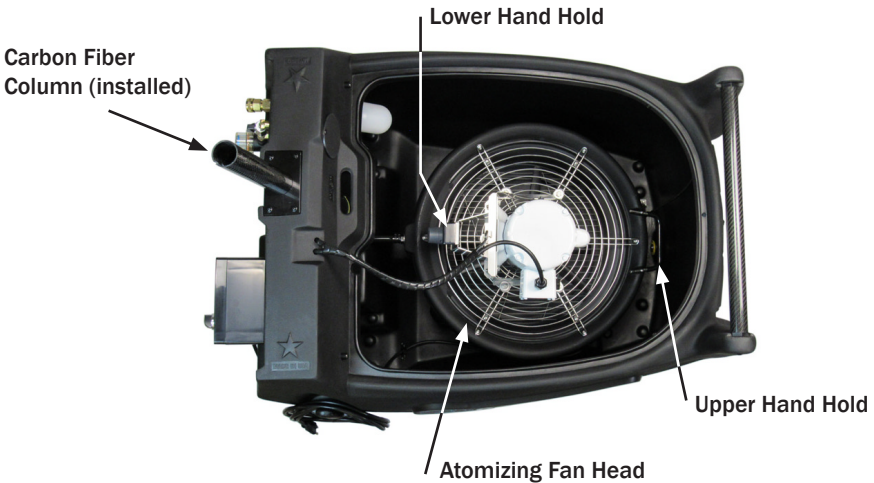

Set Up

- Locate your CoolAire unit on a level surface.
- Secure the front wheel locks.
- Install the carbon fiber column and secure (with thumb screw) at the bottom.
- Grab the two hand holds on the atomizing fan head and lift atomizing fan head into position allowing the solid (gray PVC) plug to slip inside the carbon fiber tube. Align the dowel pin to fall into the milled slot.
- Secure in place with the second (yellow) thumb screw provided.



OPERATION

After filling the tank with at least 5 gallons of water, lock the front wheels and connect the power cord. To turn ON, rotate the power switch to ON position. For mist, push on the mist switch. For sweep, push on the sweep switch. If the switch is turned to the auto-shut-off mode, push the mode START switch to activate. When tank becomes nearly empty the unit will shut down.

Sweep adjustments can be easily made by removing the red thumb screw, slide the sweep plate to a different setting and re-install the red thumb screw.

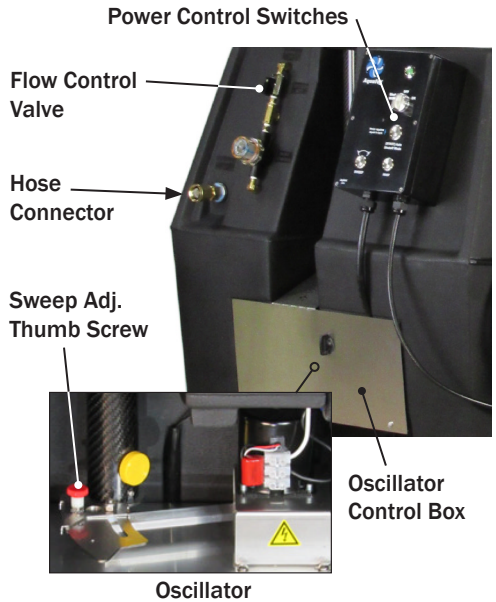

EXTENSION CORD SPECIFICATIONS*		
SINGLE UNIT USE • (AWG - American Wire Gauge)		
Voltage	25 to 50 ft.	50 to 100 ft.
115/230	16 AWG	14 AWG



*Grounded and suitable for outdoor use.

NOTICE! ALWAYS LOCK FRONT WHEELS BEFORE OPERATION ASSEMBLY OR SERVICE

WARNING! GROUND FAULT RECEPTACLES ARE RECOMMENDED AND MAY BE REQUIRED BY LOCAL AND/OR NATIONAL CODE.

MAINTENANCE

Clean Tank - A slimy tank will create issues! The tank should be rinsed and washed with mild soap regularly. Do not store or leave water in the tank when out of use.

Clean Sediment Around Pump - Periodically clean around the pump and check the in-line strainer.

Inspect Blade Assembly - Clean the exterior of the blades about once a year or whenever a film of calcium or mineral deposits is visible. While cleaning, inspect for irregularities or hairline cracks and replace as necessary.

Storage - Protect your CoolAire from winter damage. Expansion due to freezing can burst fittings, pumps and solenoids. If storing unit in below freezing temperatures, be sure to drain plumbing lines.



TROUBLESHOOTING

Issue

Tips On What To Check

**WARNING! BEFORE
INSPECTION AND/OR SERVICE
DISCONNECT AND LOCK OUT
POWER SOURCE**

@ INITIAL START-UP

- | | |
|----------------------------|--|
| 1. Fan Blade Does Not Spin | 1. Check power supply. Turn power switch to ON position mode. Check for a damaged/cut power cord. Check for loose wires inside junction boxes. |
| 2. Blade Spins but No Mist | 2. Make sure there is enough water to completely submerge the pump. The mist switch needs to be activated showing a green light. Throttle the flow control valve to maximum mist to prime out any air bubbles. Test Pump and check plumbing lines. |
| 3. Hard To See Mist Output | 3. Fine mist output is generally difficult to see without having a dark background. Fine mist particles also evaporate quickly (within seconds) in dry air. This is a good thing as this causes evaporative cooling to occur. |

SPORADIC or NO MIST

- | | |
|-----------------------------|--|
| 1. Stiff/Locked Motor Shaft | 1. If motor smells, doesn't start (with a direct power supply) or shaft will not loosen up. The motor is bad and should be replaced. |
| 2. Reduced Mist Output | 2. Check pump's output by disconnecting tubing, check pump's sediment screen. Then move up the plumbing lines looking for kinks or clogs. |
| 3. No Mist at Low Output | 3. Indicates a clogged flow restrictor tube. Remove, clean or replace. |
| 4. Worn/Bad Sump Pump | 4. Sump pumps can go bad if operated for lengthy periods of time out of water. If the pump has little to no output flow. Replace as needed. |
| 5. Clogged Fan Blades | 5. If there is a lot of calcium build-up near the end of your atomizing fan blades. Remove and clean by soaking the blade assembly in bath of (CLR) calcium dissolving solution. |

OTHER

- | | |
|----------------------------|---|
| 1. Does Not Sweep | 1. Check the sweep switch, also check the oscillator motor. |
| 2. Tank Overflowing | 2. This indicates a bad float valve. Check, service or replace. |
| 3. No Auto Shut-Off | 3. This mode requires water in the tank to activate the fluid level switch. If still not working, test the fluid level switch and replace if needed. |
| 4. Drain Plug Leaking | 4. If any deep scratches or dents occurs where the drain plug seals against the tanks wall, this can cause leaking. Attempt to smooth the walls of the hole with sandpaper. Check the plug for any damage or cracked seals. |
| 5. Plumbing Leaks | 5. If there is a persistent plumbing leak. Use both thread tape (first) with some pipe sealant on top of tape to ensure a leak-proof connection. |
| 6. Squeaky/Hot Motor | 6. If motor makes squeaky noise, smells and gets excessively hot. These are signs of a motor going bad. Replace motor early to avoid future issues. |
| 7. Control Box Not Working | 7. Check power supply and power cord. Check inside control box for loose connections. Consult an electrician or replace the control box assembly. |
| 8. Elect. Breaker Tripping | 8. Turn off all other devices connected to the same circuit. If the breaker continues to trip, the fan motor is probably bad and in need of repair. Consult an electrician for professional evaluation. |

SERVICE & REPAIR

Fan Motor/Venturi/Blade

If you need to replace the fan motor, fan blade or pinned venturi. Use a 5/32" allen wrench to remove the housing. The blade can be removed using a 3/32" allen wrench and the venturi can be removed using a #2 phillips screwdriver.



Pump Service/Replacement

Unscrew and clean the pump's sediment filter about twice a year. To replace the pump, un-wire the pump from inside the control box. Disconnect the 1/4" tubing and remove two 7/16" nuts to lift the pump out along with the stainless steel bracket. Re-attach components to the new pump and install in reverse sequence.

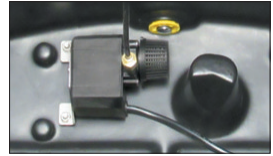

Float Valve & Fluid Level Switch

If replacing either part. Make sure to use thread tape in addition to pipe sealant to ensure a leak-proof connection.



Oscillator

If replacing an oscillator motor or a major component. It's best to remove the entire oscillator assembly and complete the task on a work bench. To remove the assembly: Un-wire the motor, remove the carbon fiber column, and unbolt the four 5/16-18 bolts underneath the stainless steel base plate.

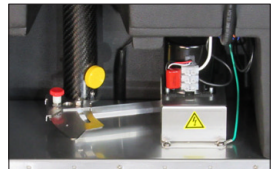

Strainer

Inspect and/or clean the in-line strainer a few times a year. The clear cover unscrews counter-clockwise (usually) by hand.

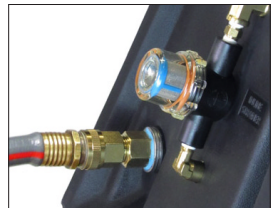

Service (peep hole)

If the atomizing fan head needs to be removed from the tank. The fans plumbing connection is accessible through the service (peep hole). This service hole is also convenient for other plumbing service procedures.



ELECTRICAL SCHEMATICS

230V 50Hz 1Ph (Foreign)

CoolAire Electrical Schematic
230 VAC 50 Hz 1 Ph

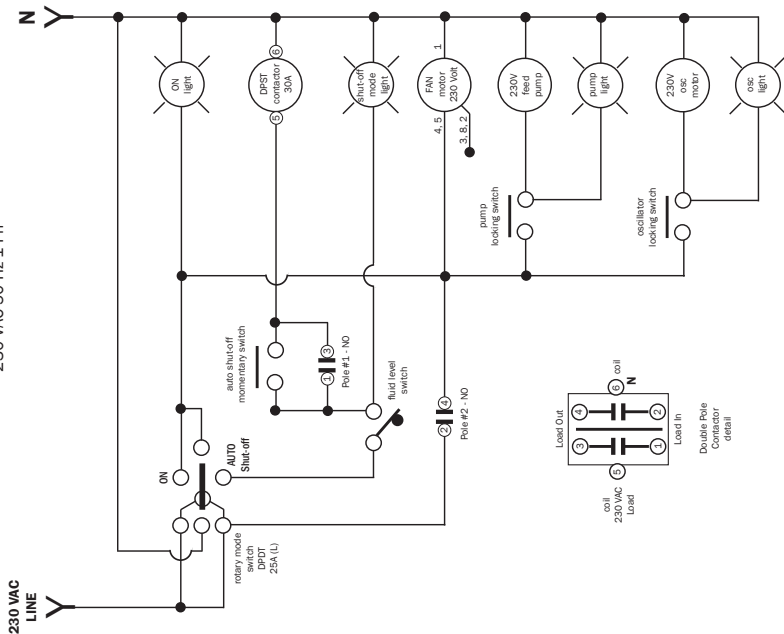

115V 60Hz 1Ph

CoolAire Electrical Schematic
115 VAC 60 Hz 1 Ph

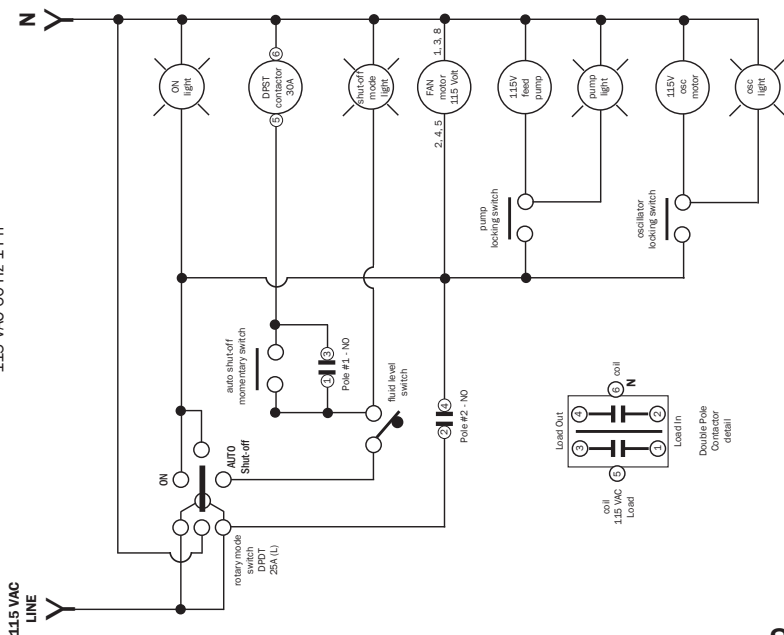

REPLACEMENT PARTS - IDENTIFICATION

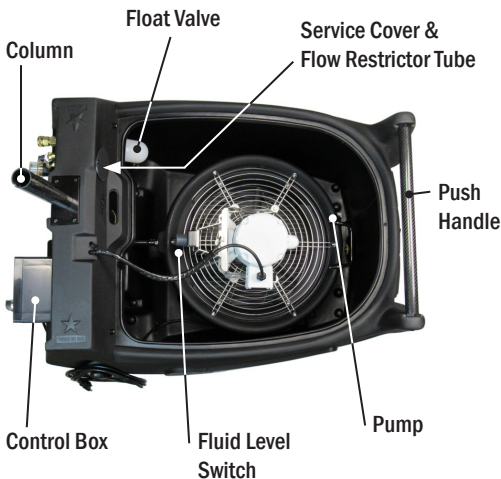

Atomizing Fan Head Parts Part No.

Fan Motor	13-500
Venturi	14
Fan Blade	531
Drain Tube	44
Fan Housing (prepped)	502-CP
Housing Hand-Hold Handle	821

Oscillator Parts Part No.

Oscillator Motor (115V)	741
Oscillator Motor (230V)	741-230
Osc. Sweep Thumb Screw	822
Osc. Control SST Cover	736
Osc. Cover Turn Knob Lock	742

Plumbing Parts Part No.

Pump (115V)	100
Pump (230V)	101
Float Valve	721
In-line Strainer	748
1/4 Turn Ball Valve	400-016
SST Flow Restrictor Tube	823
Drain Plug	793

Tank Parts Part No.

Push Handle (Carbon Fiber)	824
Tank Lid	825
Tank (prepped w/ holes)	749-P
Service (Peep-Hole) Cover	826
Front Wheels w/ Locks	715
Rear Wheels	716

Other Electrical Part No.

Fluid Level Switch	827
Elect. Control Box Assy.	828
Power Cord	507

Other Misc. Parts Part No.

Column (Carbon Fiber)	745
Thumb Screws (Column)	829



ONE YEAR LIMITED WARRANTY

Aquafog, CoolAire and accessories are warranted to the original purchaser against defects in material and workmanship under normal use for one full year from date of purchase. Any part determined to be defective and returned to the manufacturer, shipping cost prepaid, will be repaired or replaced at Jaybird Manufacturing, Inc.'s discretion without charge. Proof of purchase date and an explanation of the problem or complaint must accompany the returned portion of the machine.

Jaybird Manufacturing, Inc. reserves the right to verify the legitimacy of claimed defects. The provisions of this warranty do not apply to damage resulting from direct or indirect misuse, negligence, accident, lack of maintenance, or unauthorized repairs or alterations which affect the machine's performance or reliability.

LIMITATIONS OF LIABILITY. TO THE EXTENT ALLOWABLE UNDER APPLICABLE LAW, JAYBIRD MANUFACTURING, INC.'S LIABILITY FOR DEATH, INJURIES TO PERSONS OR PROPERTY, OR FOR CONSEQUENTIAL OR INCIDENTAL DAMAGES ARISING FROM THE USE OF OUR EQUIPMENT IS EXPRESSLY DISCLAIMED. JAYBIRD MANUFACTURING, INC.'S LIABILITY IN ALL EVENTS IS LIMITED TO, AND SHALL NOT EXCEED, THE PURCHASE PRICE PAID. NO OTHER WARRANTY, EXPRESSED OR IMPLIED, IS AUTHORIZED, INCLUDING WARRANTIES OF MERCHANTABILITY AND FITNESS FOR A PARTICULAR PURPOSE.

This warranty gives you specific legal rights, and you may also have other rights, which vary from state to state.

