

XE MOBILE ATOMIZER

USER'S MANUAL AND OPERATING INSTRUCTIONS

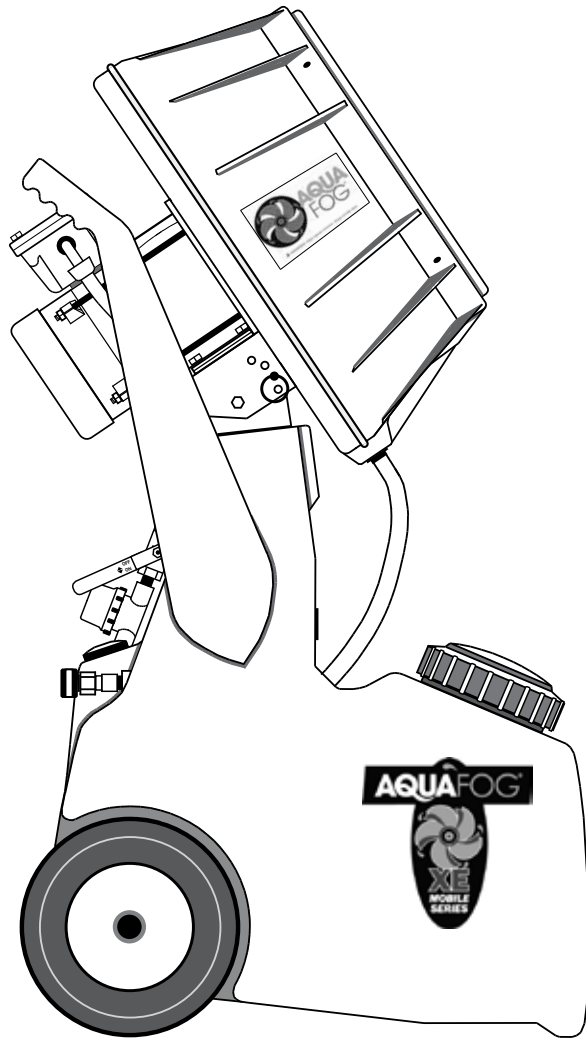

MODEL:
XE-HRSM-2000-EXP

Rear-Feed

UL and CSA Electrical Components

OPERATOR'S MANUAL

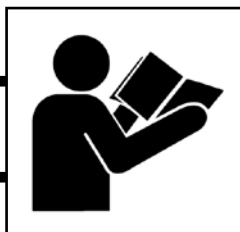

NOTICE

Read & Understand
Retain for Future Reference

TABLE OF CONTENTS

	PAGE
General Safety	3
Getting Started	4
Controls and Installation	5
Testing and Operation	6
Troubleshooting	7 - 8
AquaFog Fan Exploded View	9 - 10
HRSM Tank Exploded View	11 - 12
Maintenance	13
Warranty	14

DESCRIPTION

AquaFog mobile units are intended to condition large volumes of air using water or other non-hazardous liquids at air temperatures between 31°F and 145°F. Any other use of these units will void the warranty and the manufacturer will not be responsible for problems or damages resulting from misuse.

SAFETY GUIDELINES

This manual contains very important information. This information will help ensure SAFETY and PREVENT EQUIPMENT PROBLEMS. Use these symbols to understand safety guidelines.

 DANGER DANGER INDICATES AN IMMEDIATELY HAZARDOUS SITUATION WHICH, IF NOT AVOIDED, WILL RESULT IN DEATH OR SERIOUS INJURY.

 WARNING WARNING INDICATES A POTENTIALLY HAZARDOUS SITUATION WHICH, IF NOT AVOIDED, COULD RESULT IN DEATH OR SERIOUS INJURY.

 CAUTION CAUTION INDICATES A POTENTIALLY HAZARDOUS SITUATION WHICH, IF NOT AVOIDED, MAY RESULT IN MINOR OR MODERATE INJURY.

 NOTICE NOTICE INDICATES IMPORTANT INFORMATION, THAT IF NOT FOLLOWED, MAY CAUSE DAMAGE TO EQUIPMENT.

Notes

GENERAL SAFETY

Since the mobile HRSM-EXP uses high-speed components to atomize liquids, the following safety precautions must be observed at all times:

1. Read all manuals included with this product. Be familiar with the product and controls. 
2. The HRSM-EXP is intended to be used on level ground. Test for stability before operation.
3. Follow United States Environmental Protection Agency (EPA) guidelines and regulations when fogging pesticide or chemical solutions.
4. Follow all local electrical and safety codes as well as the United States National Electrical Codes (NEC) and Occupational Safety and Health Act (OSHA).
5. Only persons well acquainted with these rules of safe operation should be allowed to use the atomizer.
6. Keep visitors away and NEVER allow children in the work area.
7. Use of an extension cord for the HRSM-EXP is not recommended. If necessary, refer to the A.W.G chart in the following section or consult a certified electrician.
8. Before each use, inspect blade assembly and electrical components for signs of damage, deterioration, weakness or leakage. Repair or replace defective items before using.
9. Check all fasteners at frequent intervals for proper tightness.

WARNING

MOTORS, ELECTRICAL EQUIPMENT, AND CONTROLS CAN CAUSE ELECTRICAL ARCS THAT WILL IGNITE FLAMMABLE LIQUID OR GAS. NEVER OPERATE OR REPAIR IN OR NEAR FLAMMABLE LIQUID OR GAS. NEVER STORE FLAMMABLE LIQUIDS OR GASES IN THE VICINITY OF THE ATOMIZER.



NOTICE

HAZARDOUS DUTY CERTIFICATION

Baldor® Explosion-Proof motors are UL and CSA approved for the following hazardous locations:

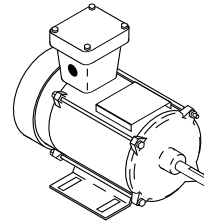

CLASS 1, Group D locations containing volatile gases such as Gasoline, Hexane, Naphtha, Benzene, Propane, Alcohol etc.

CLASS 2, Group F & G locations containing dust such as (F) Carbon Black, Coal or Coke Dust or (G) Flour, Starch, or Grain Dusts.

DANGER

HIGH-SPEED ROTATION. A MOTIONLESS ATOMIZER MAY APPEAR SAFE, BUT ITS BLADE COULD SUDDENLY BEGIN HIGH-SPEED ROTATION WITHOUT WARNING AS A RESULT OF CONTROL PROGRAMMING.

11. When this unit is automated by controls, warning signs should be posted near the high-speed equipment.



12. Disconnect and lock-out power source to inspect or service the unit.

Fogging Precautions

DANGER

DO NOT ATOMIZE FLAMMABLE MATERIALS.

13. Humidity and cold air are two common asthma triggers. Asthmatic people working with this equipment need to be made aware of the risk.



14. When atomizing toxic chemicals, follow the instructions provided by the chemical manufacturer.

GETTING STARTED

UNPACKING CHECKLIST

⚠ WARNING DO NOT OPERATE UNIT IF DAMAGED DURING SHIPPING, HANDLING OR USE. DAMAGE MAY RESULT IN BREAKAGE AND CAUSE INJURY OR PROPERTY DAMAGE.

- ▶ Un-crate carefully and position HRSM-EXP on level ground.
- ▶ Save crate and packing materials until evaluation and testing are complete.
- ▶ Read manual carefully and understand all instructions.
- ▶ Do not connect power until after thorough inspection and filling the sump with liquid.
- ▶ After filling the unit with some liquid, inspect for leaks.
- ▶ Never operate without liquid in tank.
- ▶ Be sure guards are securely in place and warnings are clearly visible.
- ▶ Check power supply for correct voltage.

ELECTRICAL

⚠ WARNING GROUND FAULT RECEPTACLES ARE RECOMMENDED AND MAY BE REQUIRED BY LOCAL AND/OR NATIONAL CODE.

⚠ NOTICE USE OF AN EXTENSION CORD IS NOT RECOMMENDED. IF NECESSARY, REFER TO FIG. 12.

Fig. 12

EXTENSION CORD SPECIFICATIONS*		
FOR SINGLE FAN USE ONLY • (AWG - American Wire Gauge)		
Voltage	25 to 50 ft.	50 to 100 ft.
115/230	16 AWG	14 AWG



* Grounded and suitable for hazardous duty locations.

UNIT PREPARATION

⚠ WARNING ENSURE THE BLADE ASSEMBLY IS FREE & CLEAR FOR START-UP (HIGH-SPEED ROTATION).

Locate a level, stable area to place the HRSM-EXP. If there's a slight grade, blocking the wheels may be necessary to keep unit secure.

Visually check to make sure the fan blades can rotate freely. There should be approximately 1/4" space between the venturi pins and the blades.

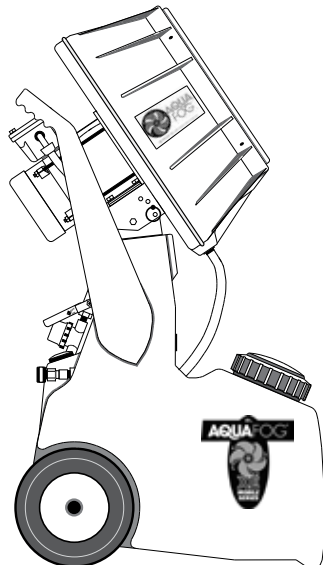

The HRSM-EXP is equipped with a four position pivoting fogging head with 15° intervals up to 45° (see Fig. 1)

Propelling the fog upward allows more time for the particles to evaporate, keeping floor areas drier.

When making an adjustment, support the weight of the fogging head off of the pin for easy removal.

Fig. 1

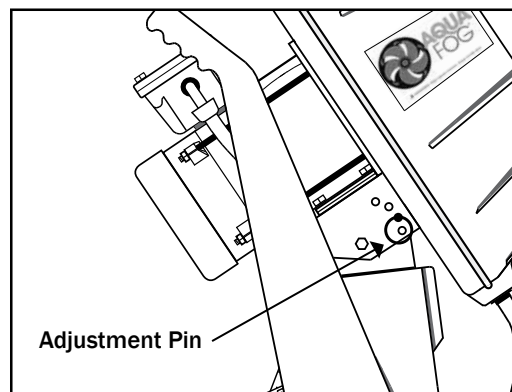

CONTROLS/ FEATURES

Operation Controls

The volume of fog can be regulated by adjusting the Flow Control Valve. (See Fig. 2)

Particle size is smaller/drier at lower outputs, so it is wise to operate the unit at a lower output for longer periods of time rather than high outputs for short periods of time.

At the base of the plumbing is an in-line strainer with a removable cap. Occasionally, check inside and flush any sediment from the screen.

The Hose Connection is used to supply fresh water to the unit and is controlled by an internal float valve assembly. There is also a secondary back up float valve assembly to ensure tank's water level.

A Fluid Level Gauge to aid in monitoring the tank's 18 gallon capacity.

Fig. 2

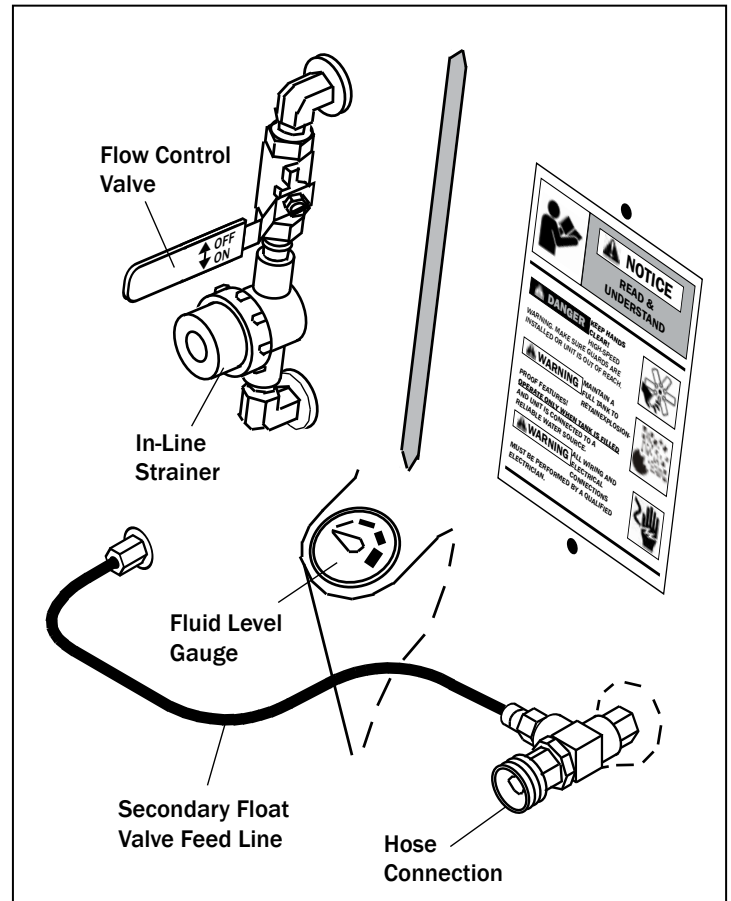

INSTALLATION

SETUPS

A) Stationary Use

For permanent installation, connect the unit's power cord directly to a hazardous duty power supply enclosure.

A) Mobile Use

Optional hazardous duty male plug can be used if switch controlled hazardous duty female receptacles are available.

Hazardous-duty enclosure with automated power supply controller. →

20A Dedicated Power Supply

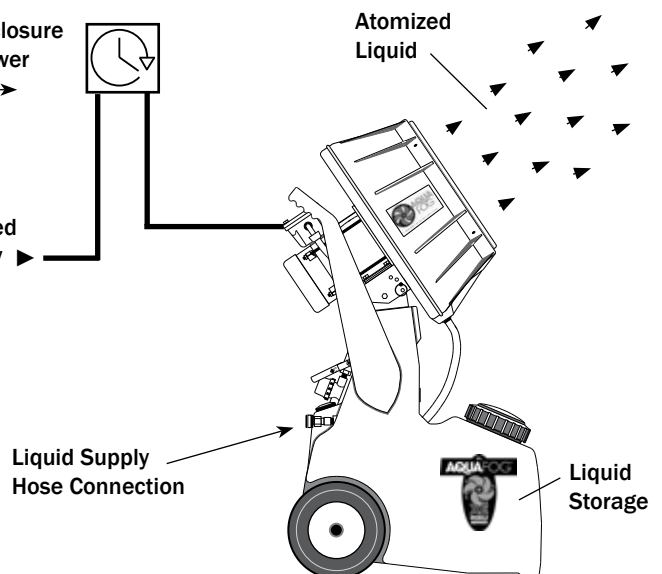
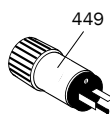

TESTING AND EVALUATION

⚠ DANGER

BEFORE TESTING FAN MAKE SURE ALL OBJECTS ARE OUT OF THE ROTATION PATH OF THE FAN BLADES. HIGH-SPEED WARNING. KEEP HANDS CLEAR! MAKE SURE GUARDS ARE INSTALLED OR UNIT IS OUT OF REACH.



- ▶ For first-time evaluation, fill tank (with water only) about one quarter full.
- ▶ Connect to power supply.
- ▶ BUMP START HRSM-EXP and check for proper fan blade rotation (clockwise if looking at front of unit). If incorrect, find rotation connection changes on the motor's electrical schematic.

⚠ CAUTION

CAREFULLY LISTEN FOR UNUSUAL NOISE OR VIBRATION.

- ▶ Turn on the unit and listen for any possible abnormalities, such as the blades rubbing against the venturi. Make re-adjustments if necessary.
- ▶ Evaluate fog quality by adjusting the output using the flow control valve. (See Fig. 2). After starting, it generally takes several seconds for the liquid to reach the atomizing fan.

OPERATION

⚠ WARNING

THIS UNIT REQUIRES A HAZARDOUS DUTY ELECTRICAL RECEPTACLE OR POWER SUPPLY



1. Operate only when tank is filled and the unit is connected to a constant and reliable water supply source (See Fig. 3). A liquid level warning is clearly posted on the back of the unit explaining the importance of maintaining an appropriate water level in the tank at all times during operation.
2. This HRSM-EXP is equipped with a back-up float valve assembly if the unit is observed operating below half-full water level, discontinue use and check the primary water fill float valve assembly for clogs, required maintenance, or possible need for replacement (See Fig. 3).

Fig. 3

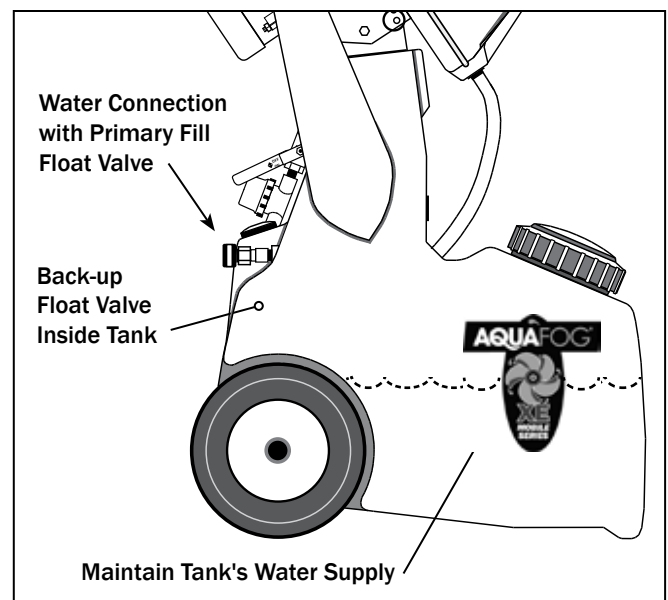

TROUBLESHOOTING



WARNING

**BEFORE INSPECTION AND /OR SERVICE,
DISCONNECT AND LOCK OUT POWER SOURCE.**

1. Fan Does Not Operate

- A.) Check voltage requirements on unit and electrical supply. Check for live receptacle, plug, and power line.
- B.) Look for any loose connections inside the main motor's junction box.

2. Blades Rub Against Venturi

- A.) To make a horizontal adjustment, loosen the 4 bolts (Part #56) at the base of the main fan motor and shift motor side to side until centered. Retighten bolts.
- B.) To make a vertical adjustment, slightly loosen 4 bolts (Part #52) and make necessary adjustments. Retighten bolts.

3. Unusual Noise

Squealing at start-up or during operation may be caused by the motor shaft's bearing seal. Spray with lubricant at the front of the motor where the shaft exits the motor's frame.

4. No Fog

- A.) Check to see if flow control valve is open. The valve is open when the handle is down and closed when up. If the valve is open and there is still no fog, the pump may need to be primed. In rare cases the pump may retain an air bubble. To prime the pump, remove the inline strainer cap (Part #71) and turn the system ON for a few seconds. Replace cap and try operating unit again.
- B.) If pump is receiving electricity but there is no fog, check for sediment in the pump's intake screen. Spray around the pump with a garden hose or remove the pump and thoroughly clean the intake screen. Clean and flush out the tank area by removing the drain plug located on the bottom rear of RSM.
- C.) If no liquid enters the tank when using the automatic fill, check float valve assembly for debris. When the float arm is up, water should shut off; when it is down, water should freely enter RSM tank.

5. Liquid Spilling From Overflow Port

- A.) Check the float valve assembly. If the float (Part #99) is filling with water, it should be replaced. Also check to see if debris is not allowing the valve (Part #97) to seal properly. Clean as needed.
- B.) Reduce the in-line water pressure.

6. Liquid Spilling From Fan Housing

If liquid builds up inside the housing, the drain tube is probably clogged. Clean debris from the drain strainer and drain tube.

TROUBLESHOOTING (CONT.)



WARNING

**BEFORE INSPECTION AND /OR SERVICE,
DISCONNECT AND LOCK OUT POWER SOURCE.**

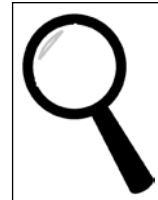

7. Poor Quality Fog

- A.) The liquid feed tube (Part #575) may not be properly positioned. The feed tube is located behind the blade assembly and should be inserted approximately 1/4" into the slot between the motor shaft and the stainless steel face plate. Centered in the slot area and aimed slightly downward, free from any rotational contact.
- B.) Liquid not traveling through the fan blades. This can be diagnosed by viewing the back of a blade assembly during operation (using a bright flashlight). If system is clogged, liquid can be seen spinning out of the slot area between the motor shaft and stainless steel face plate (Part #573). If confirmed, replace fan blade assembly (Part #571-assy). Cleaning the internal passageways of a blade assembly is feasible with the aid of some speciality tools.

8. Fan Motor Becomes Excessively Hot

The main fan motor normally becomes very hot to the touch. However, if it gets so hot that it begins to smell or smoke or the power cord becomes hot, discontinue operation and consult an electrician to properly evaluate the problem.

9. Electrical Breaker Tripping

If the electrical breaker trips off, there is an overload in the system and there may be a serious motor problem. Turn off all other devices connected to the same circuit. If the breaker continues to trip, the motor is probably in need of repair. Consult an electrician for evaluation.

10. Fan and/or Motor Vibration

- A.) If the fan unit begins vibrating severely, first be sure the blade assembly is fully engaged and securely tightened on the motor shaft. Next, inspect the blade assembly, particularly the ends of the blades. Look for wear or cracks - replace as necessary. Look for deposits of calcium or minerals - clean and remove mineral deposits and/or calcium.
- B.) If the vibration seems to be coming from the motor, first check that the motor mounting hardware is securely tightened. If hardware is secure, remove the blade assembly and operate the motor without the blade. If vibration continues, the motor has a serious mechanical problem and probably needs to be replaced.

11. Plumbing Leaks

Un-thread fittings and clean both the male and female threads. Apply new thread tape (approximately 2-3 wraps) and reconnect. If a tube fitting is leaking, tighten the cap - no more than 1 turn past finger tightened. If the leak persists, replace the tube fitting insert.

Contact Your Sales Representative for Further Assistance.

PART IDENTIFICATION

TURBO FAN EXPLODED VIEW

ID #	Description	Qty/Unit
1	Housing	1
2	Safety guard	1
7	Liquid feed tube fitting	1
8	Drain fitting	1
10-2002	Explosion-Proof motor 115V	1
14	Pinned venturi assembly	1
16	Rear guard	1
20	1/4" Heavy large diameter washer	8
32	1/4-20 nylon stop nut SST	8
35	SST washer for feed tube fitting	3
41	10-24 x 1/2" phillips RH SST	4
42	10-24 nylon stop nut SST	4
43	11/16 x 1 1/4" flat washer SST	1
49	10-24 x 1/2" TH phillips SST	4
52	1/4-20 x 3/4" HH bolt SST	4
54	1/4-20 x 3/8" button head cap screw	6
56	5/16-18 x 3/4" HH bolt SST	10
57	5/16" lock washer SST	10
58	5/16" flat washer SST	8
114	Drain fitting nut	1
115	Drain gasket	1
116	5/16-18 finish nut SST	4
117	1/4-20 x 5/8" HH bolt SST	8
288	1/8" NPT-F elbow	1
294	1/8" NPT-M x 3/8" tube fitting	1
349	5/16" brass rod	1
391	Top pivot plate	1
392	Bottom pivot plate	1
395	5/16" nylon lock nut	2
400-047	XE Faceplate screw SST	8
403	Brass ring	1
417	Machine nut	4
427	Safety guard clip	4
452	3/4" Liquid tight 90° elbow	1
454	Supertough 90° elbow	1
457	1/2" NPT aluminum coupling	1
458	1/2" NPT aluminum nipple	1
459	3/4" x 1/2" reducing bushing	1
460	3/4" EDPM O-ring	1
479	Hair pin SST	1
510	10-24 setscrew SST	2
517	SST pivot washer	2
562	Drain tubing	1.5'
568	Feed tube support SST	1
571	Turbo XE blade assembly (Ref.)	1
573	XE rear-feed faceplate SST	1
574	O-ring	1
578	Exp. stand-off	2
579	5/16" BHSCS	2
580	Exp. feed tube w/ cap	1
600-L	RSM support left	1
600-R	RSM support right	1
664	3/8" high flex tubing	2'
W-38	3/8" tubing	2.5'

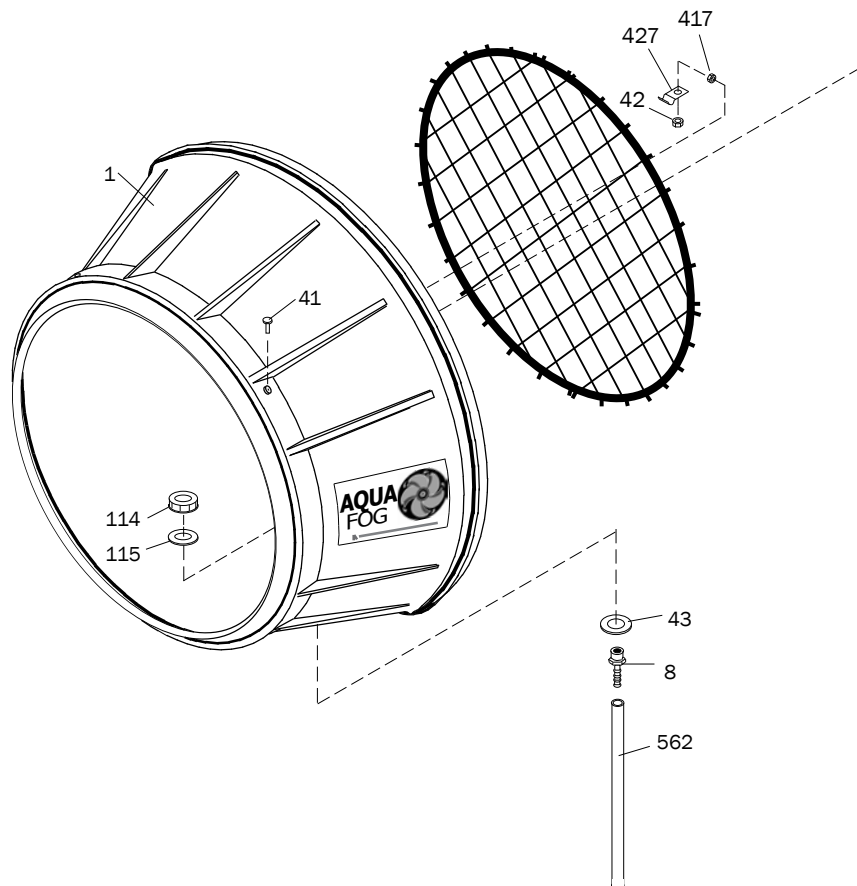

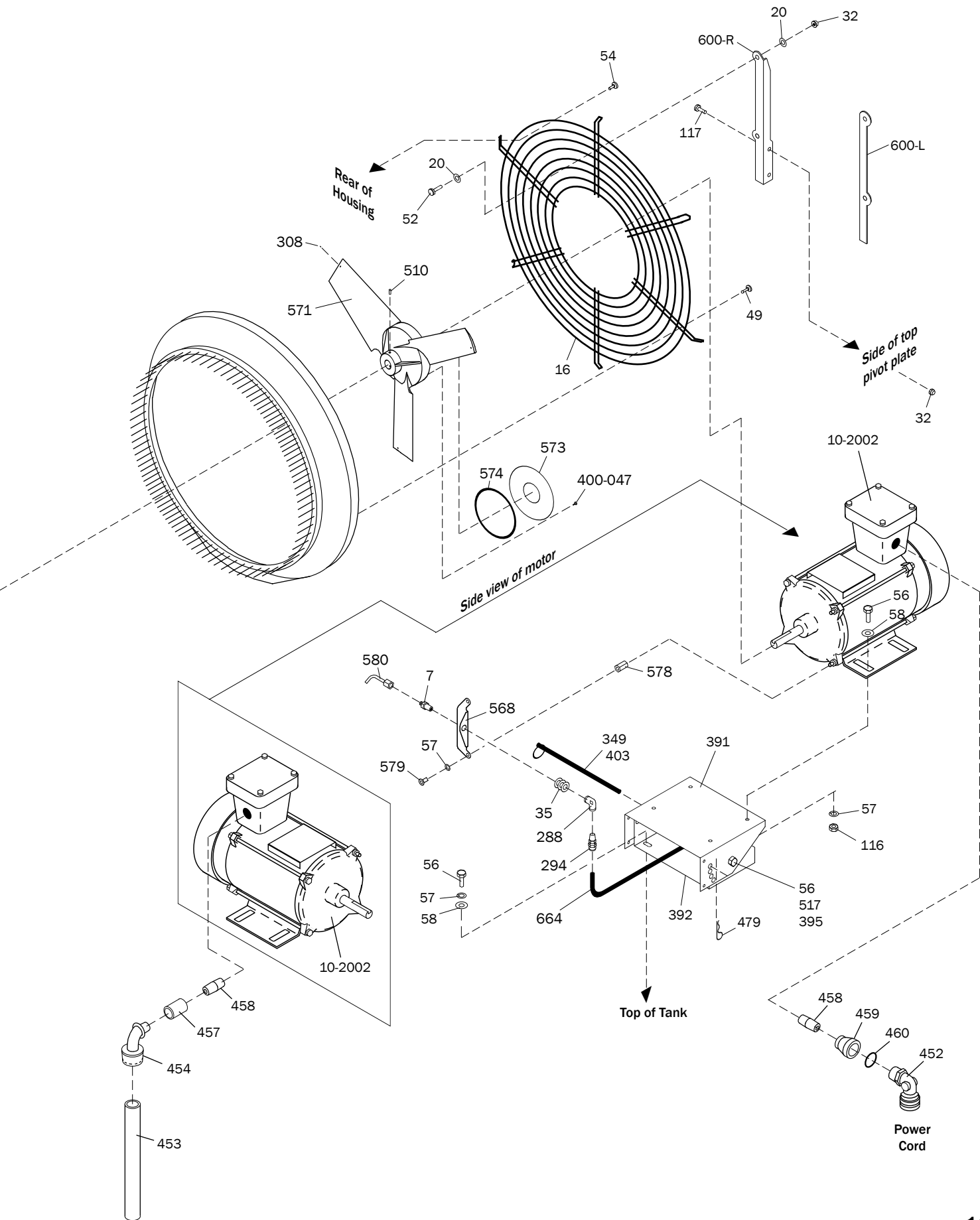

HRSM-EXP TANK EXPLODED VIEW

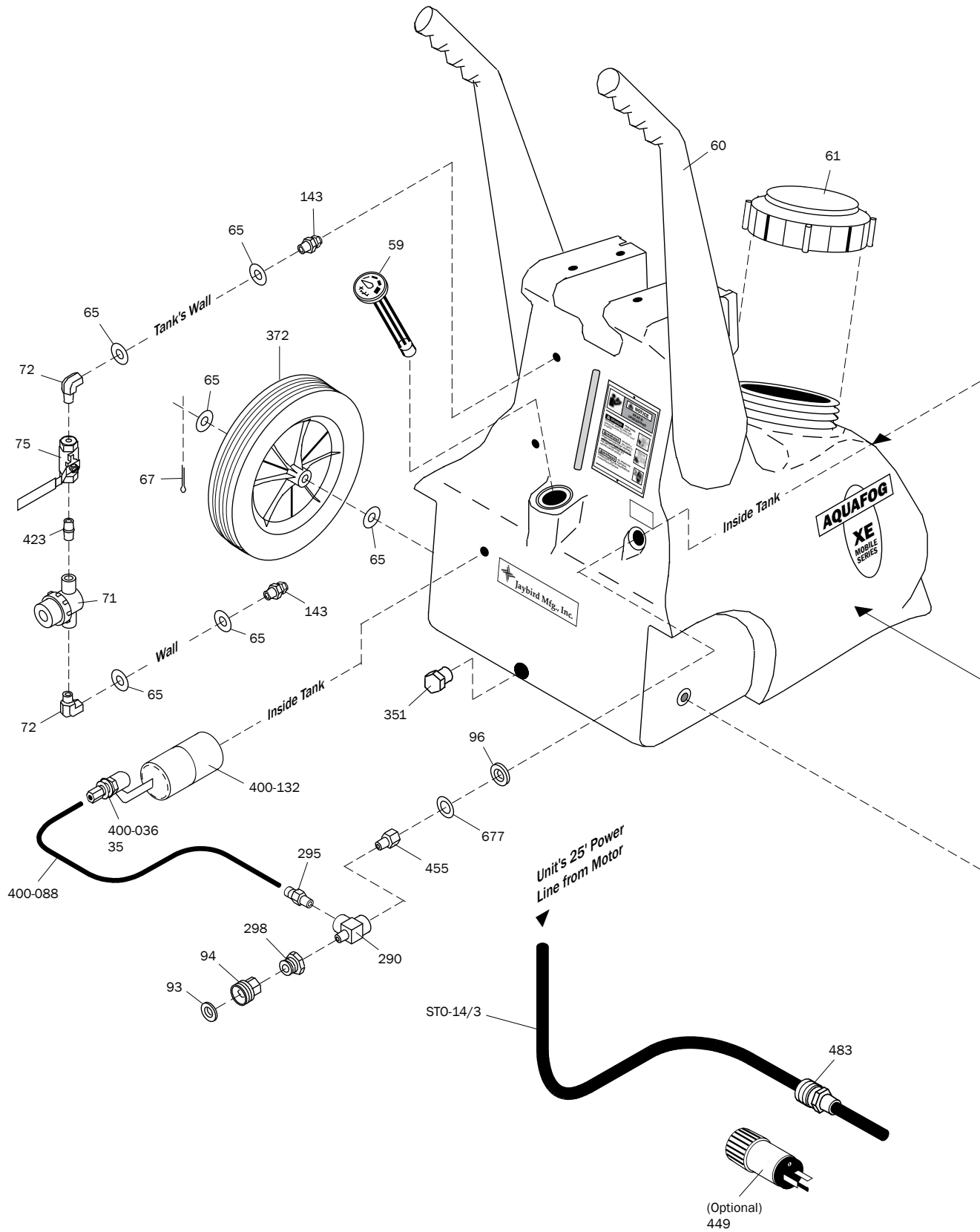

PART IDENTIFICATION LIST

PART IDENTIFICATION

ID #	Description	Qty/Unit
32	1/4-20 nylon stop nut SST	2
35	SST washer	1
55	Serrated lock washer SST	1
59	Fluid level gauge	1
60	RSM tank	1
61	Fill cap	1
65	1/2" flat washer SST	8
67	5/32 x 1 1/4" cotter pin SST	2
71	Inline strainer 1/4" female NPT	1
72	1/4" NPT street elbow	2
75	Flow control valve	1
93	Hose connector gasket	1
94	Hose connector	1
96	Gasket	2
97	Float valve	1
98	Stem	1
99	Float	1
100	Pump HRSM 115 volt 60hz.	1
108	#8 x 3/8" self tapping phillips SST	2
111	Axle SST	1
126	1/4" lock washer SST	2
143	1/4" NPT-M x 3/8 tube fitting	2
154	1/4-20 finish nut SST	2
288	1/8" NPT elbow	1
290	1/4" NPT street tee	1
294	1/8" NPT-F x 3/8 tube fitting	1
295	1/4" NPT-M x 1/4 tube fitting	1
297	1/4" NPT-F x 3/8 tube fitting	1
298	1/2" NPT-M x 1/4" NPT-F bushing	1
344	10-24 x 1/2" phillips truss head SST	4
351	1" NPT black nylon hex plug	1
372	Heavy-duty RSM wheel	2
400-036	Serrated washer SST	1
400-088	1/4" Flex tubing	2'
400-132-S	Float Valve w/ straight stem	1
423	1/4" NPT close nipple	1
443	1/4-20 x 1-1/4" HH bolt	2
449	Hazardous duty NEMA 5-20P plug	1
455	1/4" NPT-M x 1/2" NPT-F bushing	1
483	Alum. cord connector 1/2" NPT	1
606	H Pump support bracket	1
677	11/16 x 1-1/4" flat washer SST	1
STO-14/3	Hazardous duty power cord	25'

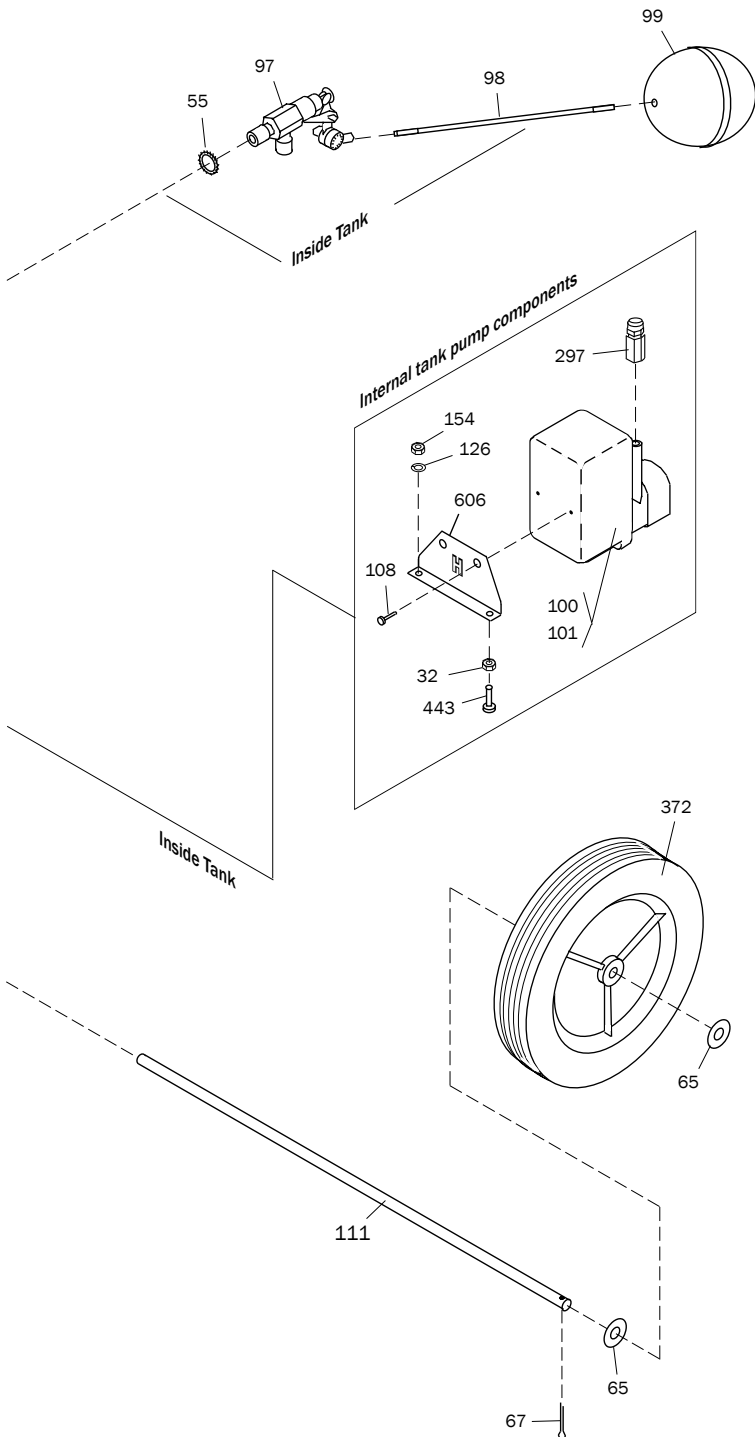

MAINTENANCE



WARNING

**DISCONNECT AND LOCK OUT POWER SOURCE
BEFORE SERVICING**

1. Clean Strainers

The RSM is equipped with 2 strainers that should be cleaned periodically - the Inline Strainer (Part #71) at the bottom of the Flow Control Valve and the Pump Screen on the Pump. Check strainers and remove any trapped debris.

2. Flush Out Tank

The tank should be rinsed regularly, especially if using chemicals. Remove drain plug (Part #351) and, using a garden hose, thoroughly flush tank and pump of any sediment.

3. Explosion-Proof Motor

The main motor is a permanently sealed and lubricated motor. Any disassembly for service or repair will void warranty and could eliminate the explosion-proof properties of the motor. If a motor should fail, a replacement motor will be required.

4. Inspect Blade Assembly

Clean the blade assembly about once a year, especially if a film of calcium or mineral deposits is visible on the exterior of the blades. Remove any build-up from the blades and any debris from blade passageways. While cleaning, inspect for irregularities or hairline cracks and replace as necessary.

5. Storage

Protect your mobile Aquafog from winter damage. Expansion due to freezing can burst the fittings or the internal feed pump. If storing unit in below freezing temperatures, be sure all fluid is drained from the tank area. Damage due to freezing is not covered under warranty.

ELECTRICAL SCHEMATIC

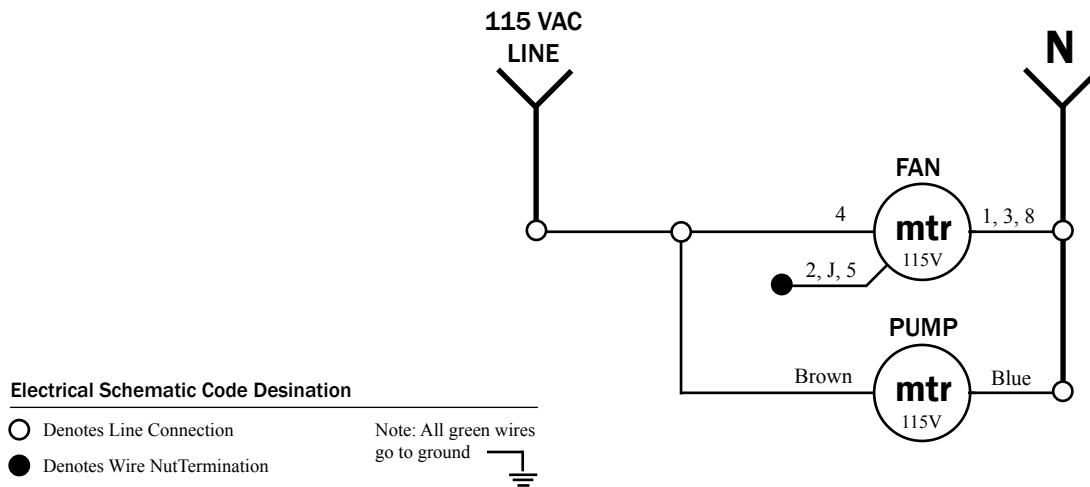



ONE YEAR LIMITED WARRANTY

AquaFog and accessories are warranted to the original purchaser against defects in material and workmanship under normal use for one full year from date of purchase. Any part determined to be defective and returned to the manufacturer, shipping cost prepaid, will be repaired or replaced at Jaybird Manufacturing, Inc.'s discretion without charge. Proof of purchase date and an explanation of the problem or complaint must accompany the returned portion of the machine.

Jaybird Manufacturing, Inc. reserves the right to verify the legitimacy of claimed defects. The provisions of this warranty do not apply to damage resulting from direct or indirect misuse, negligence, accident, lack of maintenance, or unauthorized repairs or alterations which affect the machine's performance or reliability.

LIMITATIONS OF LIABILITY. TO THE EXTENT ALLOWABLE UNDER APPLICABLE LAW, JAYBIRD MANUFACTURING, INC.'S LIABILITY FOR DEATH, INJURIES TO PERSONS OR PROPERTY, OR FOR CONSEQUENTIAL OR INCIDENTAL DAMAGES ARISING FROM THE USE OF OUR EQUIPMENT IS EXPRESSLY DISCLAIMED. JAYBIRD MANUFACTURING, INC.'S LIABILITY IN ALL EVENTS IS LIMITED TO, AND SHALL NOT EXCEED, THE PURCHASE PRICE PAID. NO OTHER WARRANTY, EXPRESSED OR IMPLIED, IS AUTHORIZED, INCLUDING WARRANTIES OF MERCHANTABILITY AND FITNESS FOR A PARTICULAR PURPOSE.

This warranty gives you specific legal rights, and you may also have other rights, which vary from state to state.

